



# **SOLSTICE<sup>®</sup>** **LIQUID BLOWING AGENT**

---

Conversion Manual

---

# TABLE OF CONTENTS

<b>INTRODUCTION</b>	<b>4</b>
Solstice® Liquid Blowing Agent (LBA) Overview	4
<b>SOLSTICE LBA TECHNICAL DATA</b>	<b>5</b>
Physical and Chemical Properties	5
Temperature Considerations	5
Physical Properties Comparison	6
Solstice LBA Physical Properties – English Units	6
Solstice LBA Physical Properties – SI Units	7
<b>FLAMMABILITY CONSIDERATIONS</b>	<b>8</b>
Flammability of Gases – Definitions and Measurement	8
Flammability Characteristics Summary	8
<b>MATERIALS COMPATIBILITY</b>	<b>9</b>
Compatibility Test Method	11
Qualification	11
Process Application Considerations	11
Gaskets and Seals: Conversion Considerations	11
<b>HEALTH, SAFETY, AND ENVIRONMENT</b>	<b>12</b>
General Safety Training	12
Material Safety	12
Hazards Common to Most Fluorocarbon Materials	12
Ingestion	13
Skin Exposure	13
Inhalation Exposure	13
Thermal Decomposition	13
Personal Protective Equipment – Solstice LBA	13
<b>BULK STORAGE VESSELS</b>	<b>14</b>
Minimum Requirements	14
Sub-systems Requirements	14
Level Measurements	14
Valves	15
Pumps	15
Gaskets	15
Pressure Relief Devices	15
Neat Solstice LBA Handling and Storage	15
Storage Vessel Inerting	15

<b>BULK STORAGE VESSELS (CONTINUED)</b>	
Tank Conversion Procedures .....	16
Solstice LBA Bulk Storage Tank Conversion .....	16
Polyol Blend Tank Conversion .....	17
<b>SOLSTICE LBA PACKAGES</b> .....	<b>18</b>
Hoses and Tubing .....	19
Cylinder Identification .....	19
Cylinder Storage .....	20
Cylinder Return Instructions .....	20
Cylinder Markings .....	21-23
Cylinder Example Images .....	24-30
<b>POLYOL (MASTER BATCH) BLENDING</b> .....	<b>31</b>
Polyurethane: Polyol Blending Operations .....	31
Solstice LBA Polyol and Polymeric Methylene Diphenyl Diisocyanate (PMDI) Miscibility .....	32
Miscibility Test Procedure .....	32
Miscibility Table: Solstice LBA in Select Polyols .....	33
Miscibility Table: Solstice LBA in PMDI .....	33
Extruded Thermoplastic Foams .....	33
<b>DRAWINGS</b> .....	<b>34</b>
Descriptive Drawings & Schematics .....	35-41
<b>APPENDICES</b> .....	<b>42</b>
Vapor Pressure of Blowing Agent – English Units .....	42
Vapor Pressure of Blowing Agent – SI Units .....	43
Vapor Pressure Comparison Charts .....	44

# Introduction

Many polyurethane, polyisocyanurate, and extruded foam applications (i.e., extruded polystyrene) that used hydrochlorofluorocarbons (HCFCs) or hydrofluorocarbons (HFCs) are transitioning to Solstice® Liquid Blowing Agent (LBA), also known as HFO-1233zd(E). It is the ultra-low global warming potential (GWP) blowing agent of choice. This is largely due to its environmental and performance properties.

This conversion manual has been developed as a part of Honeywell's commitment to a smooth transition to Solstice LBA. It has been designed to answer questions and to provide guidance on storage, handling, and processing of Solstice LBA in blowing agent applications. Chemical and physical property data, as well as related health and safety data for Solstice LBA are included in this manual. While this manual is intended to be thorough, it is not possible to cover every situation that may be found in all the manufacturing facilities around the world. Consequently, it is strongly recommended that end users consult with qualified experts to assess their particular needs, including adherence to local, regional, national, and all other applicable codes and regulations when converting to Solstice LBA.

## Solstice LBA Overview

Solstice LBA is a hydrofluoro-olefin (HFO) with the chemical structure trans-1 chloro-,3,3,3-trifluoropropene. Other nomenclature for Solstice LBA include: HFO-1233zd(E), (E)-1 chloro-3,3,3-trifluoropropene, trans-1 chloro-3,3,3-trifluoropropene, and Solstice® 1233zd(E). Hereafter in this document, Solstice LBA will be used in identifying this molecule. Solstice LBA is an ultra-low GWP replacement for HCFC-141b, HFC-134a, HFC-152a, HFC-365mfc, HFC-245a, hydrocarbons, methyl formate, methylal, water (CO<sub>2</sub>)\*, and others in foam applications. Examples include polyurethane, polyisocyanurate, and extruded polystyrene.

\* Water converts to CO<sub>2</sub> during the foaming reaction.

Solstice LBA exhibits ultra-low GWP due to the double bond present in the carbon backbone and it is non-ozone-depleting. Solstice LBA exhibits several desirable attributes:

- Chemical and physical properties similar to HFC-245fa and CFC-11
- Ultra-low GWP (GWP100 year = 1)<sup>1</sup>
- No long-lived atmospheric breakdown products<sup>2</sup>
- Non-flammable by U.S. DOT definition (reference 49 CFR 173.115)
- Non-flammable by ASTM E-681 (@23°C, ~1 atmosphere, 50% relative humidity) and EU A11 (@26°C, ~1 atmosphere) test methodologies
- Boiling Point of 66°F / 19°C
- Low order of toxicity, 800ppm 8-hour time weighted average (TWA) per U.S. Occupational Alliance for Risk Science (OARS) Workplace Environmental Exposure Level Guide (WEEL), 2013
- Compatible with commonly used metals, plastics, and elastomers
- Excellent polyol miscibility
- Good polymer melt solubility in polystyrene
- Superior foam properties, especially k-factor (lambda)

<sup>1</sup> IPCC, 2013: Climate Change 2013: The Physical Science Basis. Contribution of Working Group I to the Fifth Assessment Report of the Intergovernmental Panel on Climate Change [Stocker, T.F., D. Qin, G.-K. Plattner, M. Tignor, S.K. Allen, J. Boschung, A. Nauels, Y. Xia, V. Bex and P.M. Midgley (eds.)]. Cambridge University Press, Cambridge, United Kingdom and New York, NY, USA, 1535 pp.

<sup>2</sup> T.J. Wallington a Sulbaek Andersen b, O.J. Nielsen, 2015, "Atmospheric chemistry of shortchain haloolefins: Photochemical ozone creation potentials (POCPs), global warming potentials (GWPs), and ozone depletion potentials (ODPs)."

Due to these desirable attributes, Solstice LBA is ideally suited to replace water (CO<sub>2</sub>), hydrocarbons, methyl formate, methylal, HCFCs, HFCs, and others in many foam insulation applications where superior environmental, flammability, and foam performance is demanded. Specific technical data for Solstice LBA is included in the next section of this manual.

# Solstice® LBA Technical Data

## Physical and Chemical Properties

The properties of some common currently or previously used blowing agents compared to Solstice LBA are shown in Table 1. Certain physical and chemical properties of Solstice LBA are shown in Table 2 (English Units) and Table 3 (SI Units)\*.

\* These are but some of a mosaic of properties that must be evaluated in assessing candidate blowing agents.

Solstice LBA has properties which make this molecule an ideal low environmental impact blowing agent. It is non-flammable by ASTM E-681 (@23°C, ~1 atmosphere, 50% relative humidity) and by EU A11 (@26°C, ~1 atmosphere) test methodologies. Solstice LBA is normally introduced into the foaming process in its liquid phase. Therefore, all processing equipment, metering (flow measurement), and mixing will be in the liquid phase and, as such, associated equipment should be configured for processing liquids. Because the molecular weight\* of Solstice LBA is slightly lower than HFC-245fa, similar use levels can be realized in foam formulations. Solstice LBA is classified for transportation as a non-flammable liquefied gas under pressure.

Low GWP materials, in the context of atmospheric lifetime, often prove to be volatile organic compounds (VOC) contributing to ground level ozone formation. The measure that characterizes whether a chemical is a VOC is the Maximum Incremental Reactivity (MIR). The MIR measure at which chemicals are generally considered to be a VOC is that of ethane. The MIR of Solstice LBA has been calculated to be approximately one-fifth the value for ethane<sup>3</sup>.

<sup>3</sup> Carter, W. P. L., 2009. "Investigation of Atmospheric Ozone impacts of Trans 1-chloro-3,3,3-trifluoropropene."

Subsequently, Solstice LBA has been classified as VOC-exempt in the United States (U.S. EPA).

The European Union uses a somewhat different measure to characterize propensity for ground level ozone formation, namely photochemical ozone creation potential (POCP); "POCP is defined as the additional ozone formed in a multi-day modeling when adding a given amount of volatile organic compound relative to adding the same mass of ethene. The POCP scale is relative with the POCP for ethene defined as 100."<sup>4</sup> Solstice LBA has an estimated POCP of 3.9, which is significantly lower than the reference ethene.

<sup>4</sup> T.J. Wallington a Sulbaek Andersen b, O.J. Nielsen, 2015, "Atmospheric chemistry of short-chain haloolefins: Photochemical ozone creation potentials (POCPs), global warming potentials (GWPs), and ozone depletion potentials (ODPs)."

## Temperature Considerations

Solstice LBA has a boiling point of 66°F (19°C).

In polyurethane and polyisocyanurate foam systems, the vapor pressure that Solstice LBA exerts as part of the formulated system is formulation dependent. Factors influencing the vapor pressure include temperature, the solubility of the blowing agent in the polyol(s), the concentration of the blowing agent in the blend, and the concentration and characteristics of the other ingredients in the formulation.

In a closed blending operation, the degree of inert loading in the vessel due to the presence of nitrogen will affect the pressure in the vessel significantly\*\*. As Solstice LBA is added to the blending vessel, the pressure in the blending vessel will initially rise until solution equilibrium with the polyol is achieved. Any inert gas loading in the vessel will be additive to the pressure exerted by the vapor pressure of Solstice LBA at the temperature of the system. In some cases, this inert gas loading may result in a pressure inside the vessel that exceeds the vapor pressure of neat Solstice LBA. A vapor pressure curve for Solstice LBA and selected blowing agents, as well as other additional properties, is included in the Appendices.

\*\* Nitrogen may solubilize in the formulated system which may affect the overall system's vapor pressure.

If Solstice LBA is introduced into a polyol blend that is at elevated temperature and/or added at a rate faster than the rate of dissolution into the polyol, there is some risk of a boiling liquid and expanding vapor frothing of the polyol blend. This risk must be recognized and necessary precaution exercised to not exceed this addition rate of Solstice LBA and to ensure proper mixing conditions.

Equipment designed for foam extrusion is typically capable of handling Solstice LBA in extruded thermoplastic foaming operations. The operating conditions (pressure and temperature) of the polymer melt in the extruder are much higher than standard temperature and pressure (STP).

Optimal extruded foam production is highly dependent on the solubility of Solstice LBA into the polymer melt and the physical mixing capability of the individual extruder.

## Physical Properties\*

Property	Solstice LBA <sup>5</sup>	HFC-245fa <sup>5</sup>	HFC-365mfc/HFC-227ea blend (93/7 %by wt.) <sup>6</sup>	HCFC-141b <sup>5</sup>	Cyclopentane <sup>5</sup>
Chemical Formula	Trans CF <sub>3</sub> CH=CClH	CF <sub>3</sub> CH <sub>2</sub> CHF <sub>2</sub>	CF <sub>3</sub> CH <sub>2</sub> CF <sub>2</sub> CH <sub>3</sub> , CF <sub>3</sub> CHFCF <sub>3</sub> <sup>6</sup>	CCl <sub>2</sub> FCH <sub>3</sub>	C <sub>5</sub> H <sub>10</sub>
Molecular Weight	130.5	134	149.6 (average) <sup>6</sup>	117	70.1
Boiling point @ 1 Atmosphere (°F) (°C)	66	59.5	86 <sup>6</sup>	89.7	120.7
	19	15.3	30 <sup>6</sup>	32.1	49.2
Saturated Liquid Density @ 86°F (lb/ft <sup>3</sup> ) @ 30°C (g/cm <sup>3</sup> )	78.07	82.71	78.44** <sup>5</sup>	76.42	45.91
	1.25	1.32	1.26** <sup>5</sup>	1.22	0.74
Specific Heat of Saturated Liquid at Constant Pressure (Cp) @ 86°F (Btu/lb °F) @ 30°C (cal/kg °C)	0.298	0.32	0.33** <sup>5</sup>	0.28	0.44
	298	319	328** <sup>5</sup>	277	439
Specific Heat of Saturated Vapor at Constant Pressure (Cp) @ 86°F (Btu/lb °F) @ 30°C (cal/kg °C)	0.202	0.23	0.23** <sup>5</sup>	0.19	0.29
	202	232	226** <sup>5</sup>	193	294
Latent Heat of Vaporization @ B.P., (Btu/lb) (cal/g)	81.33	84.31	68.03** <sup>5</sup>	95.81	173.43
	45.18	46.83	37.79** <sup>5</sup>	53.22	96.35

Table 1

\*These are but some of a mosaic of properties that must be evaluated in assessing candidate blowing agents.

\*\*Properties are estimated.

<sup>5</sup>NIST Reference Fluid Properties (REFPROP) version 9.1

<sup>6</sup>[http://www.solvay.com/en/binaries/SOLKANE\\_365\\_Foaming\\_Agents-180591.pdf](http://www.solvay.com/en/binaries/SOLKANE_365_Foaming_Agents-180591.pdf)

## Solstice LBA Physical Properties\* – English Units<sup>7</sup>

Temperature (°F)	Pressure (psia)	Liquid Density (lb/ft <sup>3</sup> )	Vapor Density (lb/ft <sup>3</sup> )	Specific Heat of Saturated Liquid at Constant Pressure (Cp) (Btu/lb°F)	Specific Heat of Saturated Vapor at Constant Pressure (Cp) (Btu/lb°F)	Heat of Vaporization (Btu/lb)	Liquid Viscosity (lb/ft sec)
-40	0.805	87.949	0.023	0.292	0.172	96.906	0.001036
-35	0.963	87.579	0.028	0.292	0.173	96.289	0.000959
-30	1.146	87.209	0.033	0.292	0.174	95.675	0.000892
-25	1.357	86.837	0.038	0.292	0.175	95.063	0.000833
-20	1.599	86.464	0.045	0.292	0.176	94.454	0.000781
-15	1.876	86.089	0.052	0.292	0.177	93.845	0.000734
-10	2.191	85.714	0.060	0.292	0.178	93.238	0.000691
-5	2.548	85.336	0.069	0.292	0.179	92.632	0.000653
0	2.952	84.957	0.079	0.292	0.180	92.026	0.000618
5	3.406	84.576	0.090	0.292	0.181	91.420	0.000586
10	3.916	84.193	0.103	0.292	0.183	90.815	0.000557
15	4.485	83.809	0.117	0.292	0.184	90.208	0.00053
20	5.120	83.422	0.132	0.292	0.185	89.601	0.000505
25	5.825	83.033	0.149	0.293	0.186	88.992	0.000482
30	6.606	82.642	0.168	0.293	0.187	88.382	0.000461
35	7.469	82.248	0.189	0.293	0.188	87.770	0.000441
40	8.419	81.852	0.211	0.294	0.189	87.155	0.000422
45	9.463	81.454	0.235	0.294	0.191	86.538	0.000405
50	10.608	81.053	0.262	0.294	0.192	85.917	0.000389
55	11.858	80.649	0.291	0.295	0.193	85.294	0.000373
60	13.222	80.242	0.322	0.295	0.194	84.666	0.000359

Table 2

\*These are but some of a mosaic of properties that must be evaluated in assessing candidate blowing agents.

<sup>7</sup>NIST Reference Fluid Properties (REFPROP) version 9.1

## Solstice LBA Physical Properties\* – English Units<sup>7</sup> (Continued)

Temperature (°F)	Pressure (psia)	Liquid Density (lb/ft <sup>3</sup> )	Vapor Density (lb/ft <sup>3</sup> )	Specific Heat of Saturated Liquid at Constant Pressure (Cp) (Btu/lb°F)	Specific Heat of Saturated Vapor at Constant Pressure (Cp) (Btu/lb°F)	Heat of Vaporization (Btu/lb)	Liquid Viscosity (lb/ft sec)
65	14.707	79.831	0.356	0.296	0.196	84.034	0.000345
70	16.319	79.418	0.393	0.296	0.197	83.398	0.000332
75	18.066	79.002	0.432	0.297	0.198	82.756	0.00032
80	19.955	78.582	0.475	0.298	0.200	82.109	0.000308
85	21.994	78.158	0.521	0.298	0.201	81.457	0.000297
90	24.192	77.731	0.570	0.299	0.203	80.798	0.000287
95	26.555	77.299	0.623	0.300	0.204	80.133	0.000277
100	29.092	76.864	0.679	0.300	0.206	79.460	0.000268
105	31.812	76.425	0.740	0.301	0.207	78.780	0.000258
110	34.723	75.981	0.804	0.302	0.209	78.092	0.00025
115	37.833	75.532	0.873	0.303	0.211	77.396	0.000241
120	41.153	75.079	0.947	0.304	0.212	76.690	0.000234
125	44.689	74.620	1.026	0.305	0.214	75.976	0.000226
130	48.453	74.156	1.109	0.306	0.216	75.250	0.000219
135	52.452	73.687	1.198	0.307	0.218	74.515	0.000212
140	56.697	73.212	1.293	0.309	0.220	73.768	0.000205
145	61.197	72.731	1.393	0.310	0.222	73.009	0.000198
150	65.962	72.244	1.500	0.311	0.224	72.238	0.000192
155	71.001	71.750	1.613	0.313	0.226	71.453	0.000186
160	76.325	71.249	1.734	0.314	0.228	70.654	0.00018

Table 2

\*These are but some of a mosaic of properties that must be evaluated in assessing candidate blowing agents.

<sup>7</sup> NIST Reference Fluid Properties (REFPROP) version 9.1

## Solstice LBA Physical Properties\* – SI Units<sup>8</sup>

Temperature (°C)	Pressure (kPa)	Liquid Density (kg/m <sup>3</sup> )	Vapor Density (kg/m <sup>3</sup> )	Specific Heat of Saturated Liquid at Constant Pressure (Cp) (kJ/kgK)	Specific Heat of Saturated Vapor at Constant Pressure (Cp) (kJ/kgK)	Heat of Vaporization (kJ/kg)	Liquid Viscosity (cP)
-40	5.55	1408.8	0.3757	1.2216	0.7216	225.25	1.54
-35	7.63	1398.1	0.5064	1.2206	0.7288	222.68	1.35
-30	10.33	1387.4	0.6722	1.2201	0.7361	220.12	1.19
-25	13.77	1376.6	0.8796	1.2200	0.7436	217.57	1.07
-20	18.10	1365.7	1.1360	1.2203	0.7513	215.04	0.96
-15	23.48	1354.8	1.4492	1.2210	0.7591	212.50	0.87
-10	30.10	1343.7	1.8280	1.2222	0.7672	209.97	0.80
-5	38.16	1332.6	2.2818	1.2238	0.7756	207.42	0.73
0	47.86	1321.3	2.8204	1.2259	0.7842	204.87	0.67
5	59.44	1309.9	3.4548	1.2284	0.7932	202.30	0.62
10	73.14	1298.3	4.1964	1.2314	0.8024	199.71	0.58
15	89.22	1286.7	5.0576	1.2349	0.8121	197.09	0.54
20	107.96	1274.8	6.0515	1.2388	0.8221	194.45	0.50
25	129.65	1262.8	7.1921	1.2433	0.8324	191.76	0.47
30	154.59	1250.6	8.4945	1.2483	0.8432	189.04	0.44
35	183.09	1238.2	9.9748	1.2538	0.8545	186.26	0.41
40	215.48	1225.6	11.6500	1.2599	0.8662	183.44	0.39
45	252.10	1212.8	13.5400	1.2666	0.8785	180.55	0.36
50	293.31	1199.7	15.6640	1.2740	0.8914	177.60	0.34
55	339.45	1186.4	18.0440	1.2821	0.9050	174.58	0.32
60	390.91	1172.7	20.7060	1.2909	0.9193	171.47	0.30
65	448.07	1158.8	23.6760	1.3006	0.9345	168.27	0.29
70	511.32	1144.5	26.9830	1.3113	0.9507	164.98	0.27

Table 3

\*These are but some of a mosaic of properties that must be evaluated in assessing candidate blowing agents.

<sup>8</sup> NIST Reference Fluid Properties (REFPROP) version 9.1

# Flammability Considerations

Solstice LBA is classified as a non-flammable liquefied gas by the Globally Harmonized System of Classification and Labelling of Chemicals (GHS), United States Department of Transportation (DOT), International Air Transport Association (IATA), and International Maritime Dangerous Goods Code (IMDG) codes and regulations.

Solstice LBA is designated as a Class 2 (non-flammable) Liquefied Gas per US DOT definition (49 CFR 173.115).

## Flammability of Gases - Definitions and Measurement

The GHS defines a flammable gas as a gas having a flammable range in air at 20°C (68°F) and at a standard pressure of 101.3kPa (1 atmosphere). Similar definitions can be found in DOT, IATA, and IMDG codes and regulations.

Gases are considered to have a flammable range if they exhibit vapor flame limits, i.e., a lower flame limit (LFL) and an upper flame limit (UFL). The LFL is the leanest concentration of the gas in air that will support combustion and the UFL is the richest concentration in air that will support combustion.

Two of the commonly used tests to determine vapor flame limits are ASTM E-681 (@23°C, ~1 atmosphere, 50% relative humidity) and EU Testing Method A11 (@26°C, ~1 atmosphere): Flammability of Gases. Solstice LBA was tested according to both methodologies and found not to have a flammable range under the prescribed test conditions. Solstice LBA has an auto ignition temperature (AIT) of 380°C as measured using the DIN 51794 test methodology (see Table 4).

Evaluating blowing agent storage vessels, polyurethane processing equipment, and extruded thermoplastic foam processing operations for flammability hazard and risk exposure is a function of both the flammable characteristics of the material and possible ignition sources. Open flames are clearly an ignition source. However, some common static electricity sources are often overlooked.

## Solstice LBA Flammability Characteristics Summary

Test Methodology	Conditions	Results
ASTM E-681	23+/-3°C and 100+/-°C, 50% Relative Humidity, ~1 atmosphere	No Propagation Noted
EU Testing Method A11 - Flammability of Gases	26°C, ~1 atmosphere	Non-flammable gas
DIN51794 - AIT	~1 atmosphere	AIT = 380°C

Table 4

# Materials Compatibility

Solstice LBA is non-reactive and non-corrosive toward most commonly used metals in polyurethane, polyisocyanurate, and thermoplastic processing equipment. This includes carbon steel, stainless steel, copper, and brass. One should exercise caution with the use of aluminum due to its highly reactive nature in contact with any halogenated material, which includes Solstice LBA, particularly if aluminum fines are present. This is especially true if the oxide layer on the surface of the aluminum is removed. While it is acceptable to use copper and copper alloys for neat Solstice LBA, it is not recommended these materials be used with fully formulated polyurethane and polyisocyanurate systems.

In general, Solstice LBA is similar in compatibility toward plastics and elastomers as HFC-245fa. Gaskets and seals that were changed to accommodate HFC-245fa should be compatible with Solstice LBA. Honeywell has evaluated plastics and elastomers for use with Solstice LBA. Table 5 reports the findings of this study. For ease of reference, the compatibilities of various materials used with HFC-245fa and HCFC-141b are also included in Tables 6 and 7, respectively. Elastomers that may find application in both static conditions (for example, gaskets between flanges) versus dynamic conditions (for example, seals on rotating shafts) may have varying degrees of suitability in use.

## Solstice LBA Materials Compatibility

Substrate	Average Percentage Change		
	Hardness	Weight	Volume
<b>Plastics</b>			
HDPE	-	+1.7	+1.2
Polypropylene	-	+5.0	+3.7
PET	-	+0.1	+0.0
Nylon 6,6	-	-0.1	-0.1
Polycarbonate	-	+3.5	+3.0
PVC (Type 1)	-	+0.1	+0.0
PVDF <sup>9</sup>	-	+0.1	-0.3
PTFE <sup>10</sup>	-	+2.1	+3.9
Polyetherimide	-	+0.0	-0.5
PEEK	+1.01	-0.01	-0.33
<b>Elastomers</b>			
SBR/CR/NBR	+26	-19	-29
Buna N	+38	-15	-21
Butyl Rubber	+8.9	+1.2	-2.4
Fluoroelastomer <sup>11</sup>	-6.2	+5.6	+8.6
EPDM	+41	-28	-27
Epichlorohydrin	-0.7	+0.3	-0.5
Silicone	-1.4	-4.1	-5.9
Neoprene	+4.4	+1.0	+0.3
Perfluoroelastomer <sup>12</sup>	-10	+7	+11
Thermoplastic PU	-2.2	+8.6	+6.9

Table 5

<sup>9</sup> Used in test: "Kynar": Registered trademark of Arkema Inc.

<sup>10</sup> Used in test: "Teflon": Registered trademark of the Chemours Company

<sup>11</sup> Used in test: "Viton B": Registered trademark of the Chemours Company

<sup>12</sup> Used in test: "Kalrez 6375": Registered trademark of DuPont

## HFC-245fa Materials Compatibility<sup>13</sup>

<sup>13</sup> <https://www.honeywell-blowingagents.com/?document=honeywell-enovate-245fa-technical-brochure&download=1>

Substrate	Average Percentage Change			
	% Weight Delta	% Length Delta	% Width Delta	% Thickness Delta
<b>Plastics</b>				
Acetal	Negligible	Negligible	Negligible	Negligible
Acrylic	Dissolved	-	-	-
HDPE	Negligible	Negligible	Negligible	Negligible
Nylon	Negligible	Negligible	Negligible	Negligible
Polycarbonate	Negligible	Negligible	Negligible	Negligible
Polyetherimide <sup>14</sup>	Negligible	Negligible	Negligible	Negligible
Polypropylene	Negligible	Negligible	Negligible	Negligible
PET	Negligible	Negligible	Negligible	Negligible
PVC	Negligible	Negligible	Negligible	Negligible
PVDF <sup>15</sup>	Negligible	Negligible	Negligible	Negligible
PTFE <sup>16</sup>	Negligible	Negligible	Negligible	Negligible
<b>Elastomers</b>				
Butyl Rubber	Negligible	Negligible	Negligible	Negligible
Fluoroelastomer <sup>17</sup>	76.5	24.8	26.9	27.7
EPDM	Negligible	Negligible	Negligible	Negligible
Epichlorohydrin	10.4	3.7	3.4	2.5
Ethylene Propylene	1.2	0.8	Negligible	Negligible
Neoprene	Negligible	Negligible	Negligible	Negligible
Nitrile Rubber <sup>18</sup>	4.2	Negligible	Negligible	Negligible
Silicone	6.0	Negligible	Negligible	2.4
Urethane	20.5	2.3	5.0	9.1

<sup>14</sup> Used in test: "Ultem": Registered trademark of The General Electric Company

<sup>15</sup> Used in test: "Kynar": Registered trademark of Arkema Inc.

<sup>16</sup> Used in test: "Teflon": Registered trademark of the Chemours Company

<sup>17</sup> Used in test: "Viton A": Registered trademark of the Chemours Company

<sup>18</sup> Used in test: "Buna N"

Table 6

Negligible values indicate changes of 0.5% magnitude or less.

## HCFC-141b Materials Compatibility<sup>\*19</sup>

\* Test methodology may not be the same as described on next page.

<sup>19</sup> [http://www.virtualpu.com/uploads/user\\_doc\\_attachment/2-2013-01-23%2009:52:27-Solkane\\_141b\\_BA\\_EN.pdf](http://www.virtualpu.com/uploads/user_doc_attachment/2-2013-01-23%2009:52:27-Solkane_141b_BA_EN.pdf)

<sup>20</sup> Registered trademark of DuPont

<sup>21</sup> Registered trademark of the Chemours Company

Substrate	Compatibility
ABS	-
Nylon (6 and 66)	+
Polyethylene	-
Polypropylene	+
Polycarbonate	o
Polystyrene	-
PVC	+
PVDF	+
Epoxy Resins	+
Natural Rubber	-

Table 7

Substrate	Compatibility
Buna N	o/-
Neoprene	-
Kalrez® (Perfluoroelastomer) <sup>20</sup>	+
Silicone Rubber	-
Viton® A <sup>21</sup>	o/+
PTFE	+
Copolymere Ethyl/Propyl	-

Legend:

+ Compatible

- Non Compatible

o Compatibility to Check Case by Case

## Compatibility Test Method

- Test coupons were cut to a one-inch length and one half-inch width
- Initial weight of the individual test coupons was determined
- Test coupons were placed in sealed vials. The vials were filled with Solstice LBA and capped. Note that most test coupons' densities were less than the density of Solstice LBA such that the test coupon floated in the vial.
- Exposure time was 14 days at room temperature
- After exposure, the test coupons were removed from the vials and allowed to dry by evaporation for two minutes
- Final weight and dimensions of each test coupon was determined and reported

*Note that negligible values reported in Table 6 indicate changes of 0.5% magnitude or less.*

## Qualification

The information presented in Table 5 should be considered in the context of the evaluation that was performed. It must also be recognized that within the same family of plastic or elastomer, there may be many different manufacturers of these materials, and many different grades and quality of materials. Typically, a single material from each generic type was tested. This material may or may not be representative of the class of material, but was one that is known to be used in this class of materials.

## Process Application Considerations

The final determination of suitability for use is the responsibility of the end user. Please see Table 5 for materials compatibility information.

Prudence and consideration of the following three statements will dictate decisions on gasket and seal changeout for use with Solstice LBA.

## Gaskets and Seals: Conversion Considerations

- What is the risk exposure if the gasket/seal fails in terms of safety, environment, and economics?
- Compatibility with neat Solstice LBA does not predict compatibility with polyurethane or polyisocyanurate premixes containing Solstice LBA
- In the absence of specific compatibility data, PTFE is the recommended alternative

# Health, Safety, and Environment

The Safety Data Sheets (SDS), previously known as Material Safety Data Sheets (MSDS), for Solstice LBA accompany all shipments. These data sheets can be viewed by accessing [www.honeywellmsds.com](http://www.honeywellmsds.com). Additional copies can be obtained by contacting Honeywell at: **1-800-522-8001** or your local Honeywell office.

Solstice LBA has progressed through a battery of toxicity testing for human health effects. The Honeywell SDS for Solstice LBA contains comprehensive and the most current detail for the health, safety, and environmental aspects and considerations.

This section contains a generic fluorocarbon safety training module for Solstice LBA. This information can be utilized for in-plant safety meetings and general training seminars for employees working with Solstice LBA. This module supplements, but does not replace, the SDS. Should you desire Honeywell's assistance in this regard, contact your local Honeywell representative or Honeywell's Blowing Agent Technical Service group: **1-800-631-8138** (option 2, then option 2 again).

## General Safety Training

### Material Safety

The SDS is the most important document to accompany Solstice LBA.

- Read the SDS
- Ask for clarification if you do not understand
- Keep the SDS in a prominent location near the use area
- Follow any and all other requirements your company may have regarding SDSs. This includes but is not limited to training, periodic reviews, etc.

### Hazards Common to Most Fluorocarbon Materials

- Overexposure: Symptoms include but are not limited to dizziness, nausea, drowsiness, and may lead to unconsciousness.
- At higher levels (displacement of oxygen to <15%):
  - Central nervous system depression
  - Cardiac arrhythmia
  - Asphyxiation
  - Loss of coordination
  - Increased pulse rate and deeper respiration
- Inhalation of high concentration of vapor can lead to cardiac arrhythmia
- Because of possible disturbances of cardiac rhythm, heart stimulating drugs such as adrenaline (epinephrine) should be used with special caution and only in situations of emergency life support
- Treatment for overexposure should be directed at the control of symptoms and clinical conditions
- Rapid evaporation of the liquid may cause frostbite
- Seek medical assistance

## Ingestion

- In the unlikely event of ingestion, discomfort in the gastrointestinal tract from rapid evaporation of the material and consequent evolution of gas would result. Some effects of inhalation and skin exposure would be expected.
- Call a physician if irritation develops or persists
- If conscious, have victim swallow two glasses of water. Do not induce vomiting unless instructed to do so by a physician. Seek medical assistance.

## Skin Exposure

- Rapid evaporation of the liquid may cause frostbite
- If there is evidence of frostbite, bathe (do not rub) with lukewarm (not hot) water. If water is not available, cover with a clean, soft cloth or similar covering.
- Call a physician if irritation develops or persists

## Inhalation Exposure

- Immediately remove to fresh air
- If breathing has stopped, give artificial respiration
- If breathing is difficult, have qualified person give oxygen
- Seek medical attention for irritation or other symptoms

## Thermal Decomposition

- Fluorocarbons contain halogens (fluorine and chlorine) and should not be exposed to open flames
- Avoid contact with strong oxidizing agents and with finely divided white metals such as magnesium, aluminum, and zinc
- Thermal decomposition of HFOs, including Solstice LBA, generates toxic and corrosive materials
- Possible thermal decomposition products include halogen acids, carbon oxides, and carbonyl halides
- HFOs, such as Solstice LBA, cannot form phosgene. They can form carbonyl halides.

*Be familiar with procedures for response to skin or eye contact. Eye wash and safety shower are recommended. Typically, remove affected clothing, flush area with water for at least 15 minutes, lifting eyelids occasionally to facilitate irrigation. Seek medical attention.*

## Personal Protective Equipment – Solstice LBA

- **Skin protection:** Use protective impervious, chemical resistant gloves and clothing.
- **Eye protection:** Wear chemical resistant safety goggles.
- **Respiratory protection:** None required if used within ventilated process enclosure. Use NIOSH approved self-contained, positive pressure respirators for emergencies and in situations where air may be displaced by vapors.

# Bulk Storage Vessels

## Minimum Requirements

Storage of Solstice LBA (liquefied gas) will require a pressure vessel due to the potential for vapor pressure generation in the tank at ambient storage temperatures. Honeywell engineering guidance for bulk storage of Solstice LBA is:

- The minimum recommended design pressure rating is the vapor pressure of Solstice LBA at 130°F (54°C) plus 10% safety factor for safety device tolerance (53.30 psia, 326.79 kPa). For new installations, it is preferred to use a pressure rating of 100 psig (689 kPag) and full vacuum. Check local regulations for compliance and use the greater of the design pressure required by regulation or the recommended value above. Proper safety relief device(s) should be installed and sized appropriately.
- Storage vessels should be designed for full vacuum or have vacuum breakers installed
- Carbon steel is the recommended material of construction
- Pressurization or inerting of the tank must only be done with an inert gas such as dry nitrogen. Air should not be considered for use.
- Check all applicable code and regulatory requirements to ensure compliance if applicable

Generally, storage tanks range in size from 6,565 gallons or 24,851 liters (tank truck deliveries) to 30,000 gallons or 113,562 liters (rail car deliveries). Individual manufacturing locations should be evaluated for the most practical tank size for installation. Parameters to be considered should be consumption rates, available space, economics, and proximity to supply point.

Complete pre-engineered bulk storage systems range in sizes up to 12,000 gallons (45,425 liters). Standard sizes are 6,565 (24,851 liters), 9,200 (34,826 liters), and 12,000 gallons capacity. These packaged units consist of a storage tank, dual pumps (one of which is a dedicated spare), level gauge, filters, starter motors, piping, completely assembled and shipped via flatbed truck for installation on a concrete pad. Larger storage tanks will require foundations and pillars for support and are considerably more involved with respect to labor and material costs.

All storage tanks should be built in accordance to the latest edition of ASME Code, Section VIII, must have a "U" stamp, and must be National Board registered. Outside of the United States, the equivalent engineering pressure vessel code should be applied.

## Sub-systems Requirements

### Level Measurements

A variety of level measurement devices are commonly in use for determining the level in the storage vessel. Some of the most common and least expensive are level sight glasses and float gauges with a % full dial (Standard 0-100% Scale). Use of these is limited to determining the point at which another delivery is required, and not normally used for inventory purposes. For accurate inventory control, load cells are recommended. More sophisticated instruments can provide exact temperature and level measurements simultaneously for more accurate determination of the amount of product in the vessel (Float / Temperature device). Redundant level instruments are not uncommon in the event one of the units malfunctions or fails.

## Valves

Full port ball valves with PTFE seats and seals, carbon steel body, and stainless steel ball and stem are recommended. Gate valves with appropriate packing and adjustable packing gland are suitable for use.

## Pumps

Turbine, diaphragm, side channel multi-stage, sliding vane, or centrifugal pumps with casing pressures to match ANSI 150# class ratings are used to deliver Solstice LBA blowing agent to the polyol blend tank. These pumps should utilize PTFE mechanical seals or be sealless and magnetically coupled and driven. Consideration should be given to the installation of 2 pumps in a parallel configuration and sized properly for desired differential pressures and flow rates. Also, consideration should be given to the net positive suction head required (NPSHr), suction side strainers, and discharge side check valves.

## Gaskets

Stainless steel spiral wound with PTFE filler are recommended. Other types of gaskets such as stainless steel reinforced flexible graphite, flexible graphite, stainless steel reinforced PTFE, and 1/8" (3 mm) PTFE sheet are adequate. Before using gaskets or other elastomeric materials, refer to the compatibility chart (Table 5) earlier in this guide. Consideration of the risk exposure should the gasket fail is the prudent guidance on these choices.

## Pressure Relief Devices

Storage tanks must be protected against excessive pressure. A positive sealing valve or a rupture disc and a spring-loaded relief unit is recommended. Satisfactory materials for the rupture disc include MONEL™<sup>22</sup>, nickel, stainless steel, and silver. Relief valves used after a rupture disc can be carbon steel construction. The pressure relief device setting should equal the vessel pressure rating.

<sup>22</sup> MONEL is a registered trademark of the Special Metals Corporation

*Individual operations should choose design criteria for equipment commencing with the polyol blend tank through to the foam head on the basis of polyol blend physical and chemical characteristics or experience. Risk assessment and understanding the worst case scenario is the prudent guidance for decisions relative to this section of the process.*

## Neat Solstice LBA Handling and Storage

From the Honeywell bulk delivery trailer, through the Solstice LBA bulk storage tank to the polyol blend tank (master batch tank) or the extrusion operation, the material stream is neat Solstice LBA. All handling and processing operations with respect to the pressure ratings of vessels, gasket, and seal material compatibility, and all safety precautions relate directly to Solstice LBA.

With respect to thermoplastic extrusion operations, the material is neat Solstice LBA up to the point the material enters the extruder.

## Storage Vessel Inerting

Although it is recognized that there are specific applications that require putting an inert blanket of dry nitrogen on the Solstice LBA storage vessel, Honeywell generally recommends against this practice whenever possible as it can create issues with the delivery trailers during Solstice LBA off-loading.

If an inert atmosphere is required on a vessel, Honeywell recommends that dry nitrogen be utilized.

**Air must not be used.** Even though a fluorocarbon, such as Solstice LBA, is non-flammable, fluorocarbons combined with air or oxygen under elevated pressure and/or temperature can become flammable under certain conditions.

**CAUTION: If Solstice LBA is introduced into a polyol that is at elevated temperatures, or if the polyol blend tank has a high level of inert loading, such as nitrogen\*, excessive pressures on the polyol blend tank can be achieved. This is due to the Solstice LBA being vaporized by the hot polyol prior to complete dissolution, and/or the vapor pressure of the Solstice LBA being additive to the pressure exerted by the inert loading in the vessel. The best practice is to allow little or no inert loading on the polyol blend tank.**

\* Nitrogen may solubilize in the formulated system which may affect the overall system's vapor pressure.

# Tank Conversion Procedures

## Solstice LBA Bulk Storage Tank Conversion

- Determine tank suitability for Solstice LBA:
  - Obtain a set of tank drawings that identify tank and design criteria
  - Check ASME Data Plate – Pressure / Vacuum Rating
  - Material of Construction – Carbon Steel
- Conduct tank inspection externally:
  - Look for evidence of external corrosion – may affect pressure rating
  - Check tank shell, tank nozzles, support saddles
  - Use ultrasonic thickness gauge to determine shell corrosion
- Remove liquid (HCFC-141b, HFC-245fa, or other material) to auxiliary tank
- Remove vapor with vacuum pump to 29" vacuum
- Introduce dry air (dew point = -40°F) to atmospheric pressure
- **Use extreme caution if internal inspection is planned.** A confined space presents potential physical and chemical hazards. If a vessel is to be entered, use a recognized confined space entry procedure. Please check with your company's safety department prior to entering any tank or vessel.
- Change all gaskets to compatible gasket material
- Change all valves as indicated by compatibility assessment
- Conduct preventative maintenance and test on safety relief valves
- Pressurize tank with dry air or dry nitrogen to 50 psig to check for leaks
- Evacuate tank to 29" vacuum
- Change pump seal if indicated by compatibility testing
- Change all gaskets from pump to polyol blend tank as indicated
- Inspect and change valves from pump to polyol blend tank as indicated
- Repair/replace all grounding straps from bulk storage tank to polyol blend tank

Judicious inspection and maintenance of the bulk storage tank system during the conversion to Solstice LBA will minimize the risk of failure in the future. Honeywell representatives are available to provide assistance through the conversion process.

## Polyol Blend Tank Conversion

- Determine suitability of tank for polyol preblends containing Solstice LBA:
  - Obtain tank drawings and pressure rating
  - Test polyol blend to determine tank pressure requirements
- Inspect tank, internally and externally, for corrosion
- Inspect/repair the internal tank liner if one is present. **CAUTION!** Tank entry by personnel may be considered a "confined space entry" by your company. Specific safety rules and procedures may exist. Please check with your company's safety department prior to entering any tank or vessel.
- Ensure that Solstice LBA will be introduced below liquid level in the blend tank. If Solstice LBA addition is above the liquid level, install a dip-leg below the liquid level, or re-pipe the Solstice LBA addition to a different tank nozzle that is below the liquid level.
- Assess and change gaskets and valves as indicated by polyol blend compatibility requirements
- Service and/or test safety relief system on the blend tank
- Assess and change pump seals as indicated by polyol blend compatibility requirements
- Assess and change agitator seal as indicated by compatibility requirements.  
**CAUTION!** A robust seal arrangement to accommodate high pressures should be installed for the agitator shaft seal.
- Inspect polyol blend circulation cooling/heat exchanger
- Repair/replace all grounding straps

Storage tank conversion to Solstice LBA provides an ideal opportunity for a thorough inspection and maintenance to avoid risk of failure in the future. Inspection and preventative maintenance in a like fashion should be performed from the polyol blend tank through any auxiliary equipment to the foam head during the conversion to Solstice LBA.

## Solstice LBA Packages

Solstice LBA is supplied in a variety of packages including cylinders, isotainers, and tank trucks. Before handling or using Solstice LBA, carefully review the information in the Honeywell SDS. Copies of the SDS may be obtained by contacting Honeywell at **1-800-631-8138**, or **1-800-522-8001** (Fluorine Products) within the U.S. and Canada, or by contacting the local Honeywell sales office. The SDS may also be viewed online at the Honeywell MSDS Resource Center: [www.honeywellmsds.com](http://www.honeywellmsds.com).

All packages comply with all applicable codes and regulations for the regions in which they are transported. Honeywell supplies packages globally from various sites. Globally, package sizes, configurations, and cylinder return sites will vary from the U.S. In addition, countries outside the U.S. may have different requirements for the SDS for Solstice LBA. Customers are advised to contact their local Honeywell sales office for this information.

Honeywell has established a variety of standard packages for Solstice LBA. Typical package sizes for Solstice LBA are found in Table 8. These are subject to availability and change.

### Typical Solstice LBA Package Sizes

Region(s)	Description / actual fill wt.	Package size	Fitting type/size	Dimensions
Global	10lb/4.5kg Non-returnable Cylinder	10lb	1/4" flare	8"D x 15"H
Global	50lb/22.7kg Non-returnable Cylinder	50lb	1/4" flare	22.5"D x 19"H
Global	50lb/22.7kg Returnable Cylinder	50lb	1/4" flare liquid and vapor	22.5"D x 19"H
Global	100lb/45.4kg Returnable Cylinder	100lb	CGA 660 liquid, 1/4" flare vapor	48"H x 10"D
Global	100lb/45.4kg Returnable Cylinder Pressurized with Nitrogen	100lb	CGA 660 liquid, 1/4" flare vapor	48"H x 10"D
Global	1000lb/454kg 1/2-Ton Returnable Cylinder	½ Ton	CGA 660 liquid and vapor	56"H x 31"D
Global	1900lb/861.8kg Ton Returnable Cylinder	Ton	CGA 660 liquid and vapor	82"L x 30" D
Global	28,000-34,000lb (12,700-15,422kg) Returnable Isotainer Tank	ISO	3.25" Acme liquid 1.75" Acme vapor	20'L x 8'W
Canada and U.S.A.	~40,000lb Tank Truck	TT	2" Cam lock liquid 1.25" Cam lock vapor	20'L x 8'W
EMEAI*	6kg Returnable Cylinder Pressurized with Nitrogen	6kg	DIN 477-6 liquid	13.8"H x 9"D
EMEAI*	70kg Returnable Cylinder	70kg	DIN 477-6 liquid	45"H x 12"D
EMEAI*	70kg Returnable Cylinder Pressurized with Nitrogen	70kg	DIN 477-6 liquid	45"H x 12"D
EMEAI*	1000kg Roll Drum (RD)	Ton	5/4" BSW thread liquid and vapor	88"L x 31.5"D
EMEAI*	1000kg Cylinder Pressurized with Nitrogen	Ton	5/4" BSW thread liquid and vapor	88"L x 31.5"D
EMEAI*	12,700-15,422kg (28,000-34,000lb) Returnable Isotainer Tank	ISO	3.25" Acme liquid 1.75" Acme vapor	20'L x 8'W
Asia	800kg Ton Returnable Cylinder	Ton	CGA 660 liquid and vapor	8'L x 24"D
Canada	30lb/13.6kg Returnable Cylinder	30lb	1/4" flare liquid and vapor	17.4"H x 9.2"D

Table 8

\* EMEA: Europe, Middle East, Africa, and India

**CAUTION: Only dry nitrogen should be used to pressurize Solstice LBA cylinders. Air should never be used.**

These packages are pressure vessels with safety relief devices installed on them. Contact your local Honeywell office for package sizes and availability specific to your region. For your reference, we have included images of typical packages (see Figures 6 through 16).

The service pressure of these cylinders varies, but all meet a minimum maximum allowable working pressure (MAWP) of 260 pounds per square inch (psi), 1800 kilopascals (kPa). A schematic for nitrogen pressurization supply piping is included in the Drawings section (see Drawings 7 and 8). Furthermore, where blue arrows indicate vapor valves on the cylinder images, this represents where nitrogen would be added. Most packages can be pressurized with nitrogen, however, European 6kg, European 70kg returnable cylinders, and Global 10lb/4.5kg and 50lb/22.7kg non-returnable cylinders cannot be pressurized.

Specific details and specifications with drawings of some of these packages are included in the Drawings section (see Drawings 1 through 8). Care must be exercised in orienting horizontal one-ton cylinders such that the valves are in the vertical orientation.

## **Hoses and Tubing**

### **Basic Requirements:**

Hose or tubing materials of construction must be compatible with Solstice LBA (see Materials Compatibility section). They must also be rated appropriately for the temperatures and pressures for which they will be subjected (both positive pressure and full vacuum).

### **For cylinders:**

Hoses designed and used for refrigerants or tubing made from perfluoroalkoxy alkane (PFA) are commonly used. Typical size is 1/4" inner diameter (ID), but larger diameters may also be used.

### **For Isotainers and Tank Trucks:**

Hoses that are PTFE (or other compatible material) lined and structurally reinforced are necessary. Typical sizes for Isotainers are 2" (ID) for the liquid and 1" (ID) for the vapor. Typical sizes for Tank Trucks are 2" (ID) for the liquid and 1.25" (ID) for the vapor.

## **Cylinder Identification**

Cylinders can be identified by the following information stamped on the cylinder:

- Owner's name (Honeywell)
- Regulatory specification number for the cylinder (DOT, TC, etc.)
- Serial number
- Date of test, month, and year
- Manufacturer's symbol
- Water capacity in pounds

For your assistance, we've provided guidance on how to interpret cylinder markings (see Figures 2 through 5).

Some cylinder sizes described are returnable, and should be returned to Honeywell. For cylinder returns, please contact your local Honeywell account representative or Honeywell customer service.

For the U.S., please follow the cylinder return instructions on the next page (Figure 1).

## Cylinder Storage

Store Solstice LBA packaged cylinders in a dry, ventilated, enclosed area away from heat, flame, corrosive chemicals or fumes, and explosives. Avoid direct sunlight, particularly in warm weather.

**Do not allow a cylinder to get warmer than 122°F (50°C).** Solstice LBA cylinders should always be raised above dirt or damp floors to prevent rusting. All containers must be secured in place by means of a rack or chain, so they cannot tip, roll, or accidentally strike each other or any other object.

## Cylinder Return Instructions (Continental U.S.A.)

1

**Provide Information**

- Number and size of cylinders
- Product last contained

2

**Contact Schneider Logistics at 1-866-681-5160**

- Schedule pick up and provide Bill of Lading

3

**Review**

- Is the Bill of Lading accurate?

4

**Shipment Requirements and Freight**

**Affix Tags**

- DOT tags are required for **every** cylinder
- DOT hazmat information contained on the product label must be legible
- When returning a damaged cylinder an **additional** "Return for Inspection" tag is required
- For additional tags contact Schneider Logistics (1-866-681-5160)

**Palletize Cylinders**

- All cylinders must be properly palletized

**Instructions for Damaged Returns**

- Disposable cylinders must be in original carton which contains all of the required DOT information
- Shrink wraps and seals must be intact
- All approved product credits will be applied within 30 business days of cylinder receipt

**Freight**

- Freight prepaid by Honeywell provided minimums are met
- Minimums do not apply to damaged cylinders

**Minimum Return Requirements**

Cylinder Size	Number of Cylinders
Ton	1
½ Ton	1
200 lb cylinder	9
100-125 lb cylinder	12
50 lb cylinder	24
25 lb cylinder	40
10 lb cylinder	40

*Damaged cylinders can be combined with empties*

**NOTE: Full or partial cylinders containing a Class 2.1 (flammable gas) must be secured and transported vertically**

Honeywell Customer Service: 1-800-522-8001 / fpcustomer@honeywell.com

Figure 1. How to Return Empty and Damaged Cylinders for Honeywell Refrigerants, Blowing Agents, Aerosols and Solvents (Continental USA Only)

# Cylinder Markings – UN Pressure Receptacles<sup>23</sup>

<sup>23</sup> [http://phmsa.dot.gov/staticfiles/PHMSA/DownloadableFiles/Files/PHH50\\_0078\\_0706\\_UN\\_Cylinders.pdf](http://phmsa.dot.gov/staticfiles/PHMSA/DownloadableFiles/Files/PHH50_0078_0706_UN_Cylinders.pdf)

## What types of markings appear on UN pressure receptacles?

### TOP ROW

Contains manufacturing marks such as the cylinder thread type, the country of manufacture, and the serial number assigned by the manufacturer.

### MIDDLE ROW

Contains operational marks such as the test pressure, the tare or empty weight, and the minimum wall thickness.

### BOTTOM ROW

Contains certification marks such as the UN packaging symbol, the ISO standard, the country or countries of approval, and the manufacturer's approval mark.

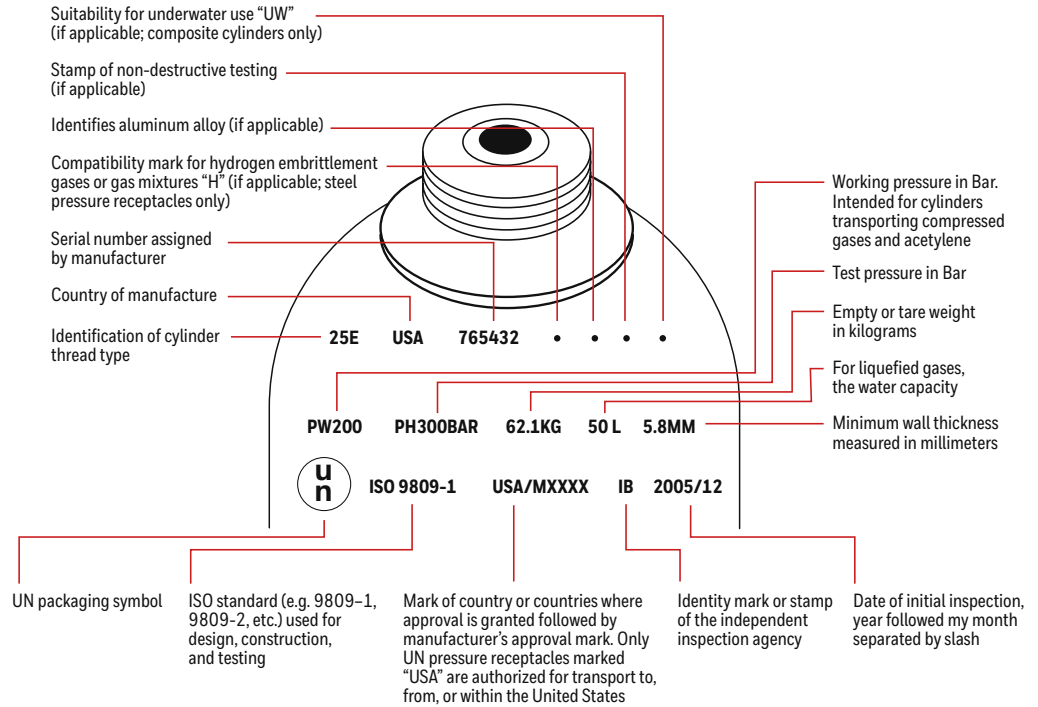

Other markings are permitted in other low stress areas provided they are not on the side wall. The markings must not conflict with the required markings.

Figure 2

## Cylinder Markings - Canada<sup>24</sup>

<sup>24</sup> [https://info.budgetpropaneontario.com/hs-fs/hub/242267/file-252155043-png/images/propane\\_cylinder-resized-600.png](https://info.budgetpropaneontario.com/hs-fs/hub/242267/file-252155043-png/images/propane_cylinder-resized-600.png)

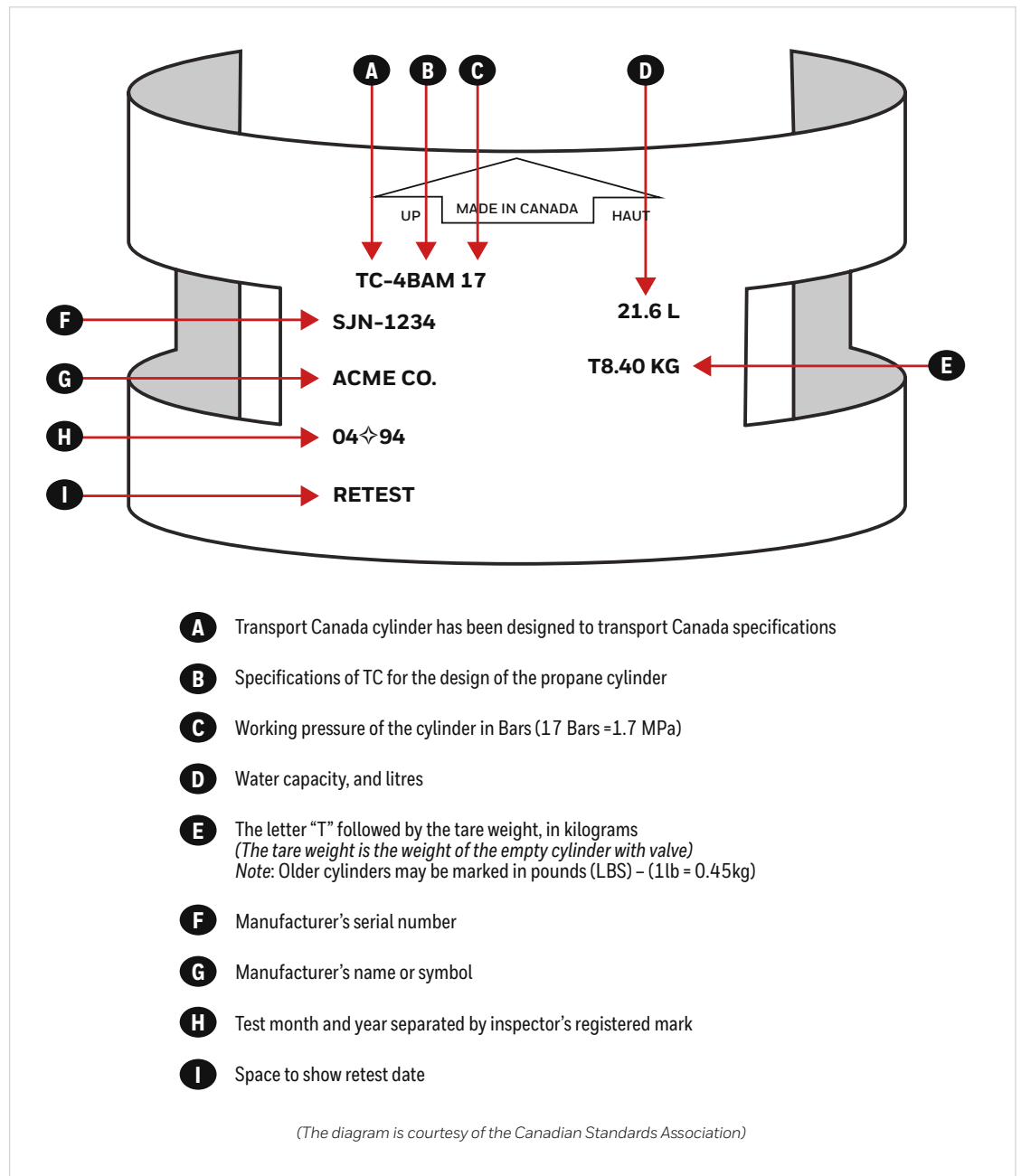

Figure 3

## Cylinder Markings US DOT<sup>25</sup>

<sup>25</sup> [https://trainex.org/osc2012/uploads/516/40\\_Sec%205%20-%20Cylinder%20Identification%202.pdf](https://trainex.org/osc2012/uploads/516/40_Sec%205%20-%20Cylinder%20Identification%202.pdf)



Figure 4

## Cylinder Example



Figure 5

## Solstice LBA 10lb/4.5kg Non-Returnable Cylinder

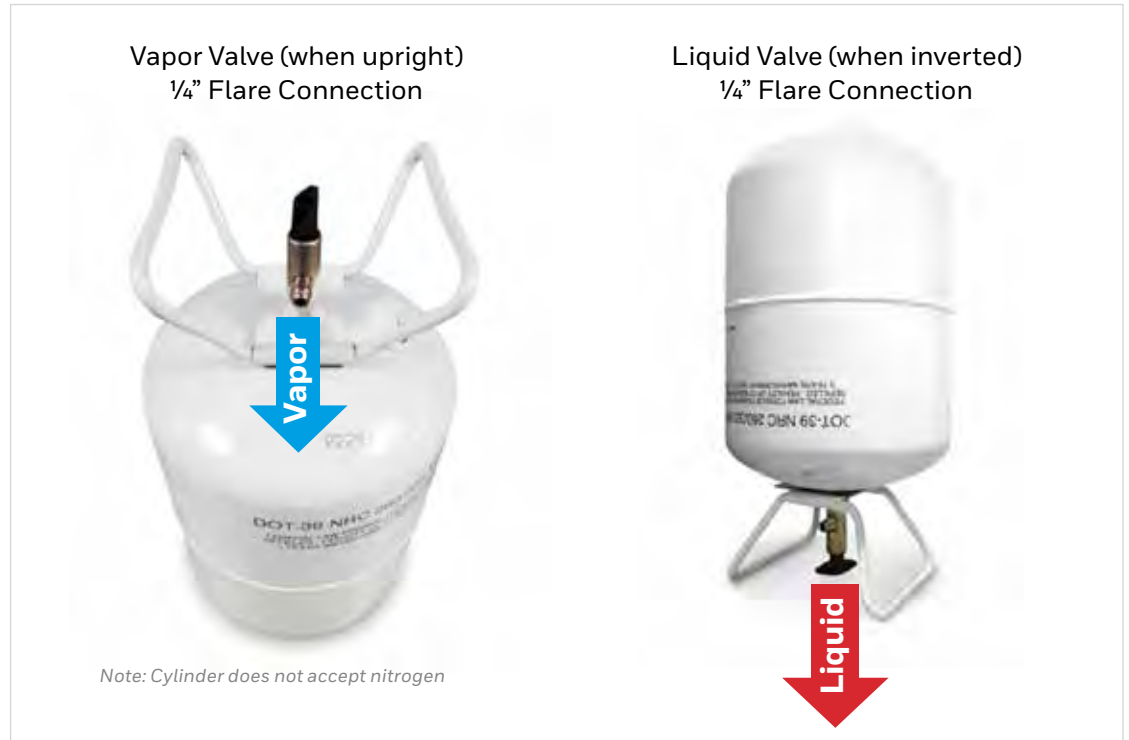

Figure 6. Global except EMEA and Canada

## Solstice LBA 50lb/22.7kg Non-Returnable Cylinder

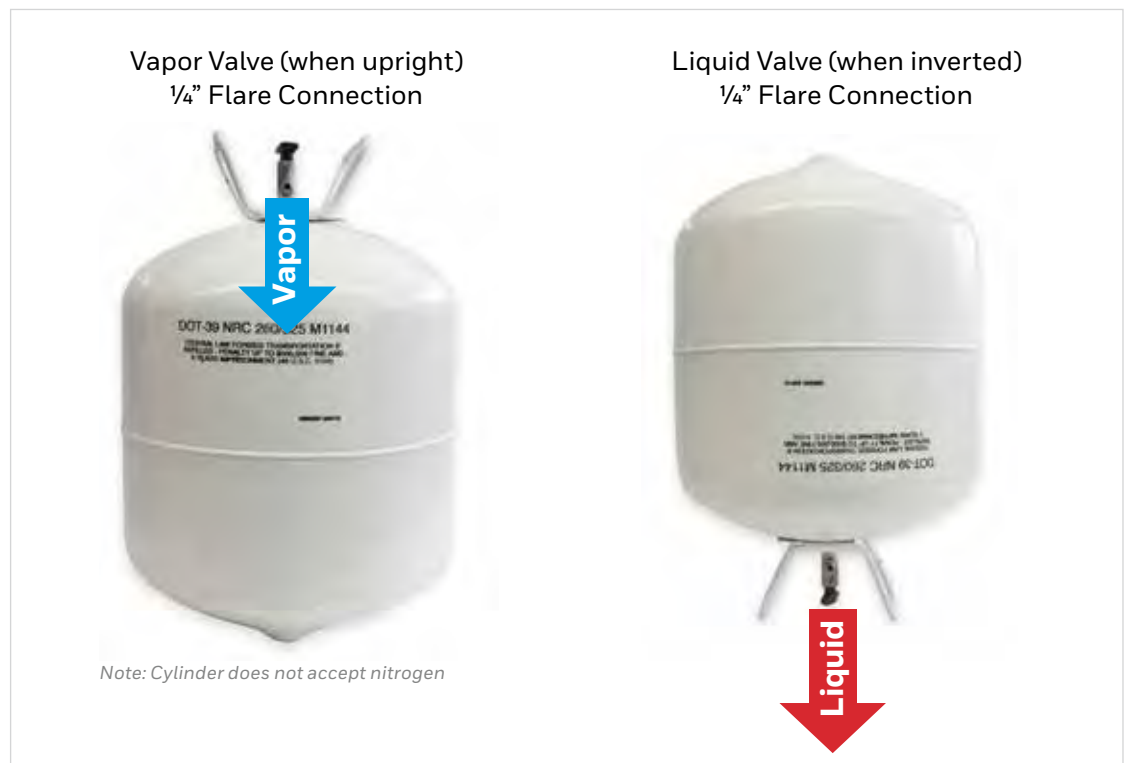

Figure 7. Global except EMEA and Canada

## Solstice LBA 50lb/22.7kg Returnable Cylinder

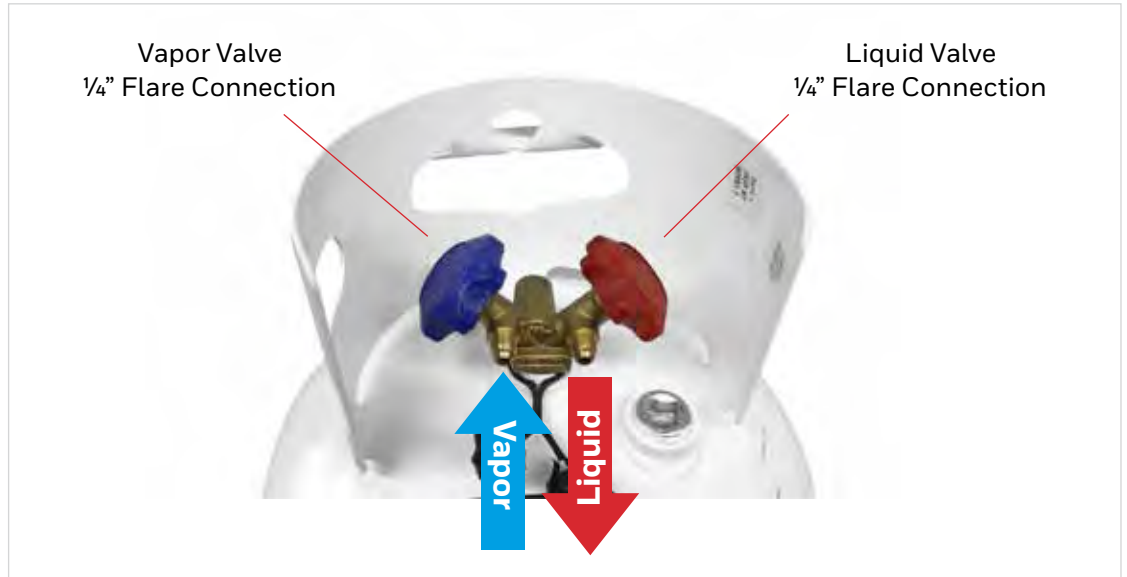

Figure 8. Global except EMEA and Canada

## Solstice LBA 100lb/45.4kg Returnable Cylinder

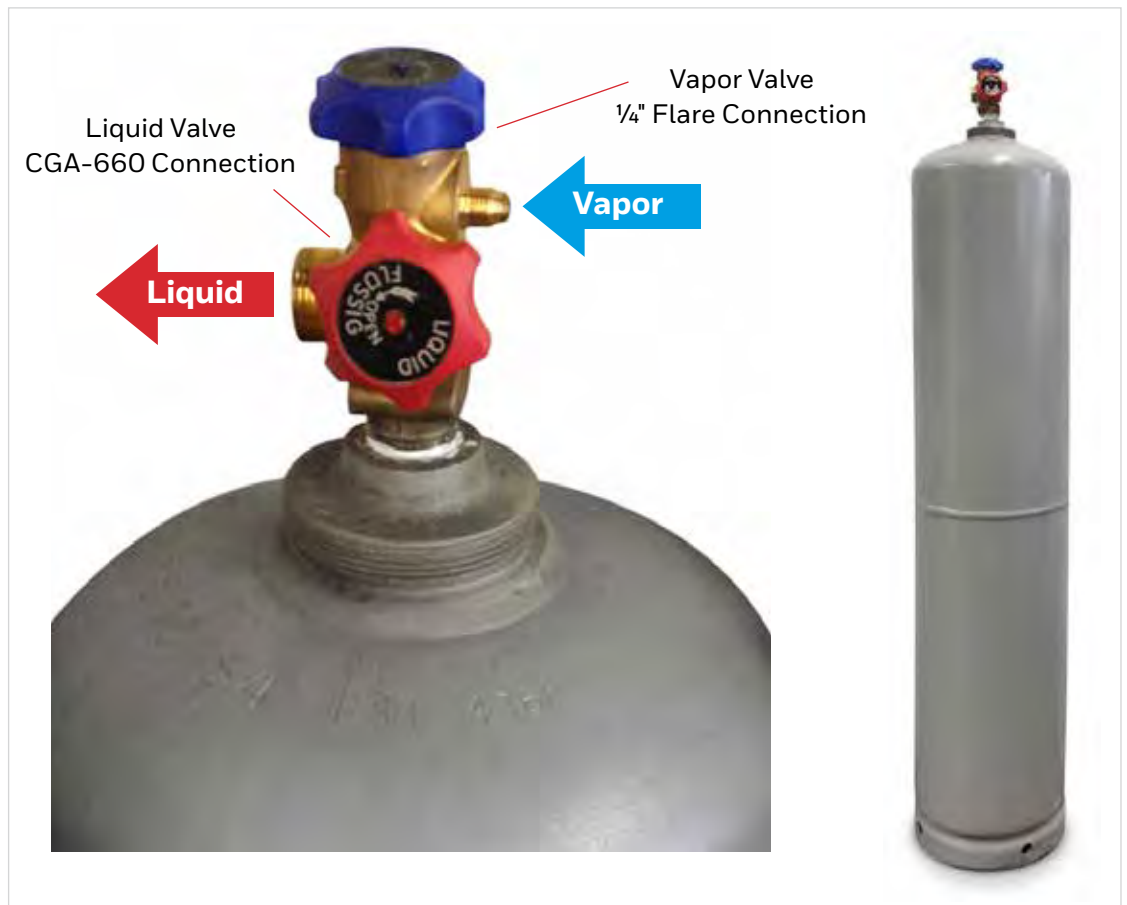

Figure 9. Global/Canada except EMEA with and without nitrogen

## Solstice LBA 1000lb/454kg ½ Ton Returnable Cylinder

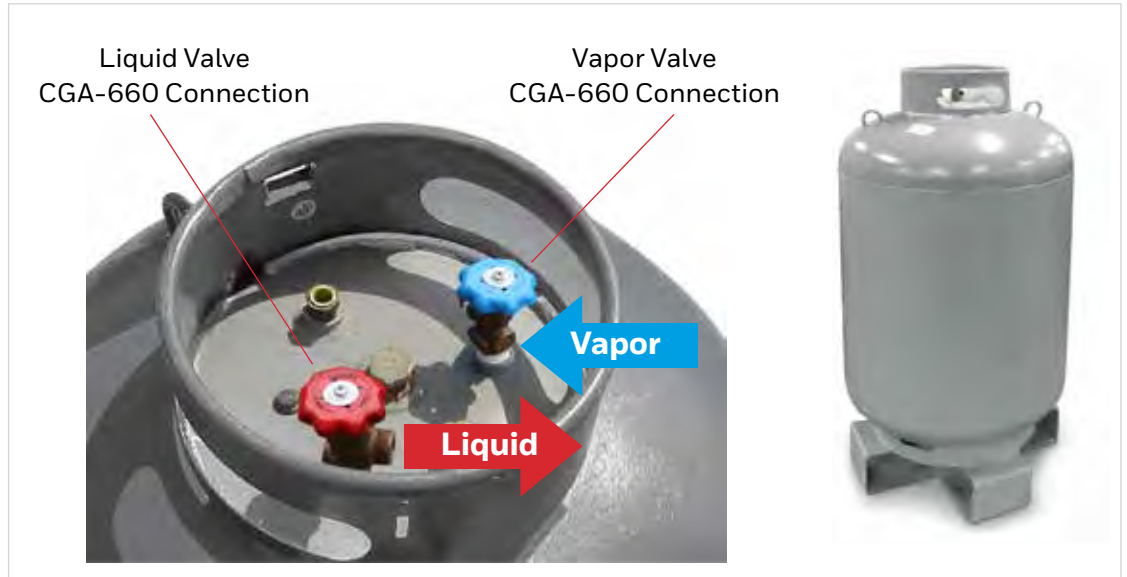

Figure 10. Global except EMEAI and Canada

## Solstice LBA Ton Returnable Cylinder

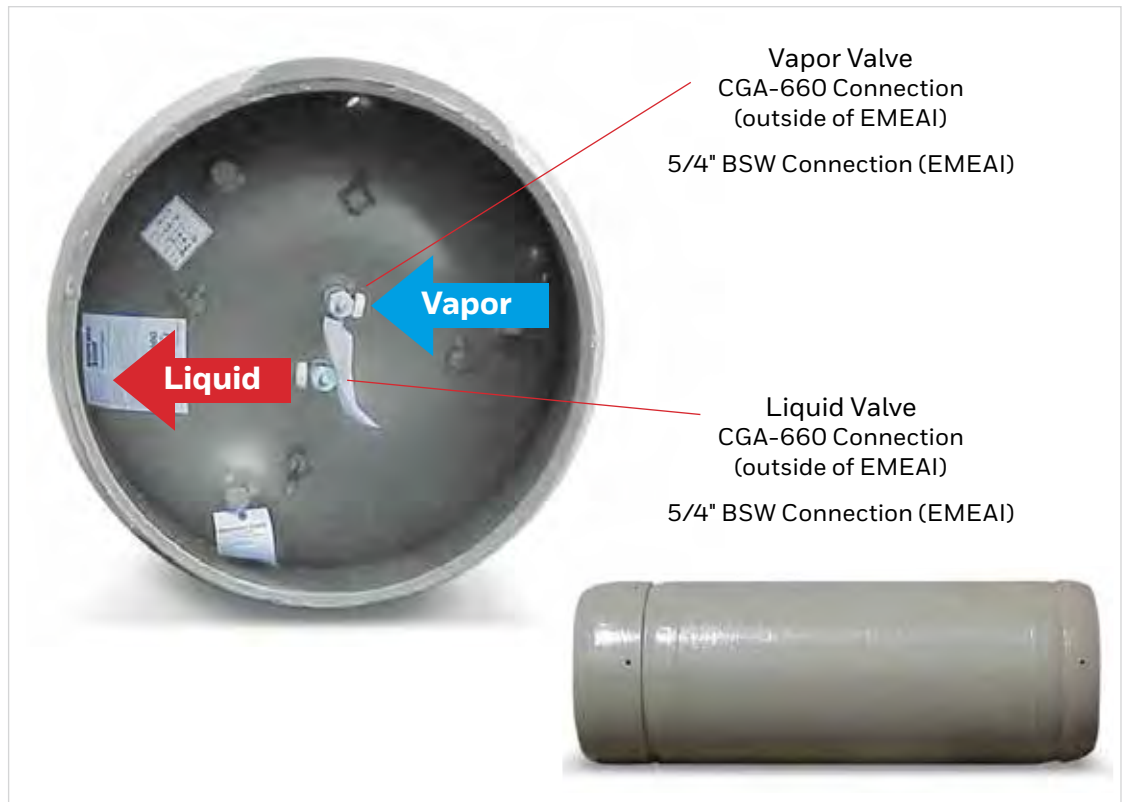

Figure 11. Solstice LBA 1900lb/861.8kg Ton Returnable Cylinder (Global/Canada except EMEAI)  
 Solstice LBA 800kg Ton Returnable Cylinder (Asia)  
 Solstice LBA 1000kg Roll Drum with and without nitrogen (EMEAI)



## Solstice LBA 40,000lb Tank Truck

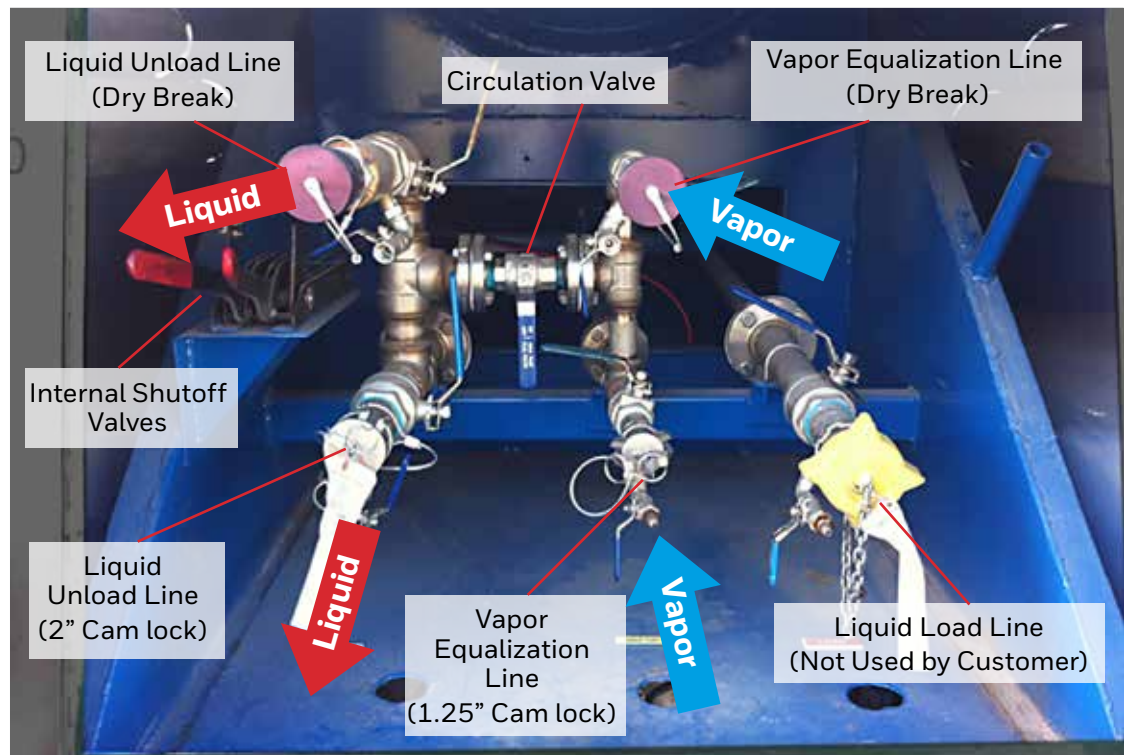

Figure 13. (Canada and U.S.A.) Note: Valve and piping configurations may vary by truck.

## Solstice LBA 6kg Returnable Cylinder



Figure 14. (EMEAI)

## Solstice LBA 70kg Returnable Cylinder



Figure 15. With and without nitrogen (EMEAI)

Solstice LBA 30lb/13.6 kg Returnable Cylinder

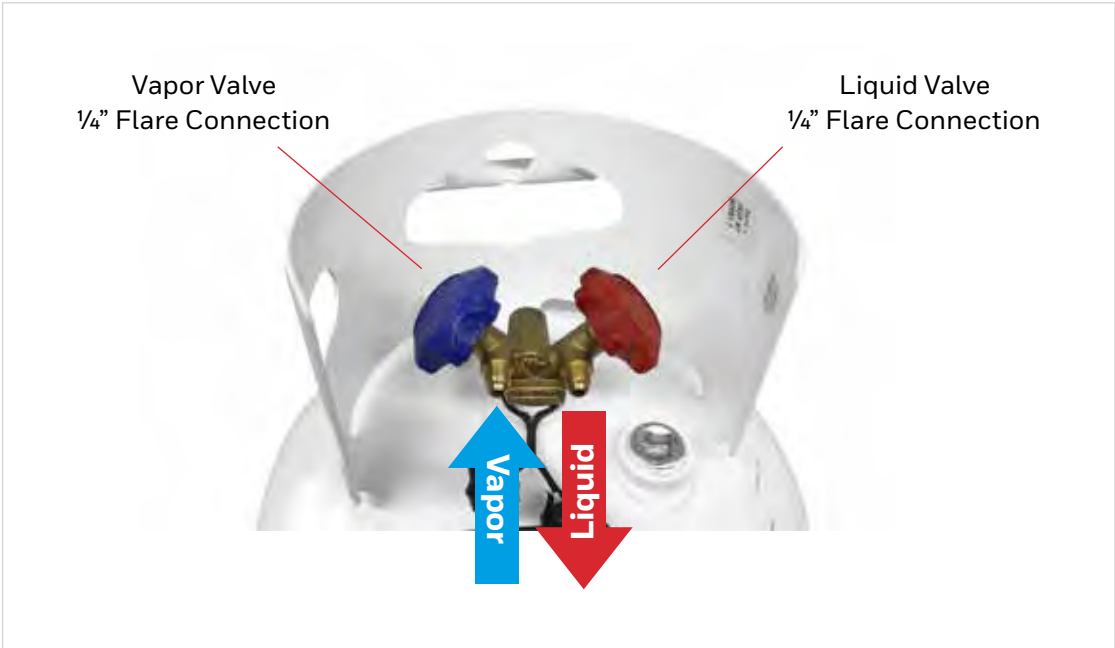

Figure 16. (Canada)

# Polyol (Master Batch) Blending

## Polyurethane: Polyol Blending Operations

In general, preparation of a polyurethane or polyisocyanurate polyol master batch, or polyol premix, is accomplished by the measurement and blending of the polyol (or polyol blend) with all other ingredients (surfactants, catalysts, water, and others) except blowing agent, into a suitable master batch vessel. The blowing agent is then incorporated, as a final step, into the polyol master batch to complete the fully formulated system.

**CAUTION:** *Circulating polyol blend piping configuration should not allow the liquid to 'free-fall' through the vapor space. Free falling organic materials have the potential to build up a static electrical charge and can froth the tank.*

Due to the nature of Solstice LBA, i.e., liquefied gas under pressure with a boiling point of 66°F (19°C), one must take care to properly process the material in its liquid state. Proper equipment and methods must be used to safely manage this process; some examples are listed below. Closed loop blending in temperature controlled, pressure-rated equipment is considered a best practice and is recommended. Although open blending is not recommended, it is important to optimize the process and minimize blowing agent losses if it used. Here are key considerations: maintain the polyol premix and blowing agent below the boiling point, add the blowing agent below the liquid level while stirring, and ensure the addition rate of the blowing agent is less than the dissolution rate of the blowing agent into the polyol. One also must be cautious of the material boiling out of a polyol premix causing frothing.

Efficient and uniform blending of Solstice LBA into polyol is impacted by the bulk temperature of the polyols. Furthermore, temperature of the polyol introduces a separate complexity to any blending operation.

- Solstice LBA may vaporize out of the polyol (into the polyol blend vessel head space) at typical ambient temperatures and especially at elevated temperatures. Cooling the polyol can help to minimize this effect.
- Polyols, in general, are relatively viscous materials, with the viscosity increasing with lower temperatures. This increase in viscosity not only presents a challenge with Solstice LBA solubility into the polyol, but increases the difficulty of pumping and stirring the polyol. At the extreme, if the polyol is very viscous, two separate layers of polyol and Solstice LBA will form in the blend vessel.

The fully formulated polyol master batch blend, containing blowing agent can be accomplished by any of several methods. Some illustrative examples are:

- Master batch tank blending, in which the Solstice LBA is added directly into the polyol blend vessel. The blowing agent should be added below the liquid level of polyol in the blend vessel. This may be accomplished by either: 1) a circulation return flow below the polyol liquid level; or 2) by a dip pipe below the polyol liquid level.
  - The polyol blend vessel contains a paddle type stirring mechanism
  - The polyol blend may additionally be circulated from the bottom of the blend tank, and the circulating polyol returned below the liquid level in the polyol blend vessel, to mitigate stratification and ensure uniform mixing.
- Addition of Solstice LBA in master batch blending as described above may also include the use of a static mixer in a circulation loop, wherein the Solstice LBA is added at the static mixer.
- Separate blowing agent blending equipment wherein liquid Solstice LBA is blended into a circulating polyol stream
- Addition of Solstice LBA via commercially available mechanical blending systems. These types of systems are available from most major polyurethane equipment suppliers and are suitable for Solstice LBA.

*NOTE: These are general polyol blending procedures, and it should be noted that variations on these processes may be indicated by the process configuration in the polyurethane or polyisocyanurate foaming operation in the individual manufacturing plants.*

It should be noted that to assure accuracy and repeatability of the fully formulated polyol system, all ingredients should be accurately measured by utilization of a scale or load cells on the master batch blend vessel; or alternatively, the ingredients are metered by accurate flow measurement devices.

Honeywell recommends using a closed, pressure-rated tank for polyol blending. The tank should preferably be designed for use with neat Solstice LBA at elevated temperature (130°F/54°C plus 10% safety factor). At a minimum, it must be designed to accommodate the vapor pressure of the polyol blend.

Alternatively, Solstice LBA may also be added via a mechanical blending system (see pg. 31) as a third stream at or near the foam head either directly or to the polyol or isocyanate streams before the head via an inline mixer.

### **Solstice LBA Polyol and PMDI Miscibility**

Formulation development and blowing agent blending into the polyol master batch and/or isocyanate is an important part of the production of polyurethane and polyisocyanurate foams. One of the main factors to be considered when developing formulations or designing polyol blending systems is the miscibility of the blowing agent in the polyol premix. The miscibility of a sampling of polyols and PMDI materials are represented in the following tables. Consult Honeywell or the material suppliers for additional information on the miscibility of Solstice LBA in raw materials.

### **Miscibility Test Procedure**

A mixture containing various compositions of Solstice LBA and polyol or isocyanate is prepared in a glass pressure reaction vessel, also commonly known as a Fisher-Porter tube. The mixture is thoroughly mixed at an elevated temperature (86°F / 30°C) and then placed in a constant temperature bath (75°F / 24°C) for 24 hours. The height of the polyol or isocyanate and of Solstice LBA blowing agent is measured and the miscibility is noted by visual observation. The maximum weight percent for miscibility of the mixtures are summarized in Tables 9 and 10.

If the mixture is turbid, cloudy, or not uniform, the appearance is noted and it is allowed to equilibrate until a constant separation is measured.

## Miscibility of Solstice LBA in Select Polyols

	Polyol Name	Maximum Wt% for Single Phase Solution	Polyol Name	Maximum Wt% for Single Phase Solution
Suppliers:	<b>Polyether</b>		<b>Polyester (Continued)</b>	
<sup>26</sup> Registered trademark of Carpenter Co.	Carpol® GSP-280 <sup>26</sup>	>40	Phantol® SV-29B <sup>35</sup>	35
<sup>27</sup> Registered trademark of Huntsman	Jeffol® A630 <sup>27</sup>	>40	Phantol® JP-733 <sup>35</sup>	29
<sup>28</sup> Registered trademark of Covestro LLC	Multranol® 3901 <sup>28</sup>	>40	Phantol® 6300 <sup>35</sup>	44
<sup>29</sup> Registered trademark of BASF	Pluracol® 824 <sup>29</sup>	>40	Phantol® 6301 <sup>35</sup>	35
<sup>30</sup> Registered trademark of The Dow Chemical Company	Voranol® 270 <sup>30</sup>	>40	Phantol® 6305 <sup>35</sup>	>50
<sup>31</sup> Registered trademark of Stepan	Voranol® RH360 <sup>30</sup>	>40	Stepanol® 2352 <sup>31</sup>	>40
<sup>32</sup> Registered trademark of Invista	Voranol® 350X <sup>30</sup>	>40	Terate® 2031 <sup>32</sup>	~11
<sup>33</sup> Registered trademark of Oxid LP./ Data provided by manufacturer	Voranol® 470X <sup>30</sup>	>40	Terate® 2540 <sup>32</sup>	40
<sup>34</sup> Registered trademark of Kawasaki Kasei Chemicals LTD./Data provided by manufacturer	Voranol® 490 <sup>30</sup>	>40	Terate® 4020 <sup>32</sup>	~20
<sup>35</sup> Registered trademark of Hitachi Kasei Polymer Co. LTD./Data Provided by manufacturer	Voranol® 800 <sup>30</sup>	>40	Terol® 198 <sup>33</sup>	40
			Terol® 250 <sup>33</sup>	40
	<b>Polyester</b>		Terol® 256 <sup>33</sup>	25
	Maximol® RDK-133 <sup>34</sup>	25	Terol® 305 <sup>33</sup>	26
	Maximol® RDK-121 <sup>34</sup>	25	Terol® 352 <sup>33</sup>	23
	Maximol® RDK-142 <sup>34</sup>	25	Terol® 925 <sup>33</sup>	21
	Phantol® PL-272 <sup>35</sup>	24	Terol® 1254 <sup>33</sup>	39
	Phantol® PL-306 <sup>35</sup>	16	Terol® 1304 <sup>33</sup>	47
	Phantol® PL-405 <sup>35</sup>	19	Terol® 1465 <sup>33</sup>	25
	Phantol® SV-208 <sup>35</sup>	37	Terol® 1481 <sup>33</sup>	30

Table 9. Miscibility at 75°F (24°C) of selected polyols

## Miscibility of Solstice LBA in PMDI

MDI Name	Maximum Wt% for Single Phase Solution
Lupranate® M20S <sup>36</sup>	>10
Lupranate® M70R <sup>36</sup>	>10

<sup>36</sup> Registered trademark of BASF

Table 10. Miscibility at 75°F (24°C) of selected PMDI

## Extruded Thermoplastic Foams

With an extruded thermoplastic foaming process, such as extruded polystyrene (XPS) and others, the blowing agent is added directly into the polymer melt in the extruder. Liquid blowing agent is introduced, usually via a pump through a metering device to the extruder without significant regard to temperature, as the polymer melt is at elevated temperatures.

Solstice LBA will be handled as a neat material from the storage vessel, through the feed pumps, directly to the extrusion operation. Therefore, all materials of construction through this part of the process should be compatible with neat Solstice LBA.

As with most other blowing agents, the extrusion operation will likely include the use of one or more co-blowing agents. Judicious and appropriate choice of co-blowing agent(s) will be determined by the foam manufacturer in accordance with finished foam requirements, either thermal or mechanical, and the configuration and capability of the individual extrusion operation. The addition of co-blowing agent(s) to the extruder will be a separate addition directly to the extruder, and may or may not be at the same location in the extruder as the Solstice LBA.

## Drawings

A variety of drawings and schematics have been included in this manual to illustrate and describe the ideas and processes written in this document.

**Drawing 1** is the layout and general specifications for a Solstice LBA bulk storage vessel. As is described in this document, standard fluorocarbon storage tanks come in sizes ranging from 6,565 gallons or 24,851 liters (tank truck size) to 30,000 gallons or 113,562 liters (rail car size). This drawing is the pressure vessel design (at the time of this manual's publication) in which the delivery vessel unloading lines (liquid and vapor) are located on the bottom of the tank. Older tanks currently in service may have both unloading lines on the top of the bulk storage vessel.

**Drawing 2** gives additional detail for the Solstice LBA bulk storage system. This drawing shows the schematic for the pumping station, as well as additional detail on the bulk storage vessel. This drawing reflects a standard, skid-mounted bulk storage system.

**Drawing 3** shows the process schematic and illustrates a Solstice LBA bulk delivery trailer connected to the Solstice LBA bulk storage tank. As is described in this document, Solstice LBA is available in cylinders, in addition to bulk shipments.

**Drawing 4** illustrates the two types of one-ton cylinders that are utilized in fluorocarbon service. Note that there are differences in concave and convex heads on the cylinder. Also observe the configuration of the liquid and vapor valves and internal legs. This illustrates the importance of proper cylinder orientation to effectively transfer Solstice LBA from the ton cylinder to the process.

**Drawing 5** is a schematic of an unloading station for one-ton cylinder operation. Note the orientation of the liquid and vapor valves on the cylinder on the vertical axis.

**Drawing 6** illustrates a process flow diagram for Solstice LBA from the liquid and vapor lines that connect to the bulk tank, through to the foam head. This schematic is typical of many polyurethane operations; however, individual operations may have some differences in the process equipment or configuration.

In Drawing 6, the dashed line toward the bottom of the page separates the typical operations of a systems house, from an operation such as may be found in a refrigerator manufacturing facility or a boardstock manufacturing facility. A polyurethane systems manufacturer would stop with the fully formulated polyol and proceed to packaging and shipping for their ultimate end-use customer. In a refrigerator or boardstock operation, the blended polyol system would proceed forward to additional holding tanks or day tanks, and subsequently to the foam head.

There is a section in this document describing Solstice LBA packages (see pg. 18).

**Drawings 7 and 8** illustrate a typical piping (tubing) configuration for Solstice LBA removal and use from a 100lb cylinder and a one half-ton cylinder.

## Bulk Storage Vessel Specifications

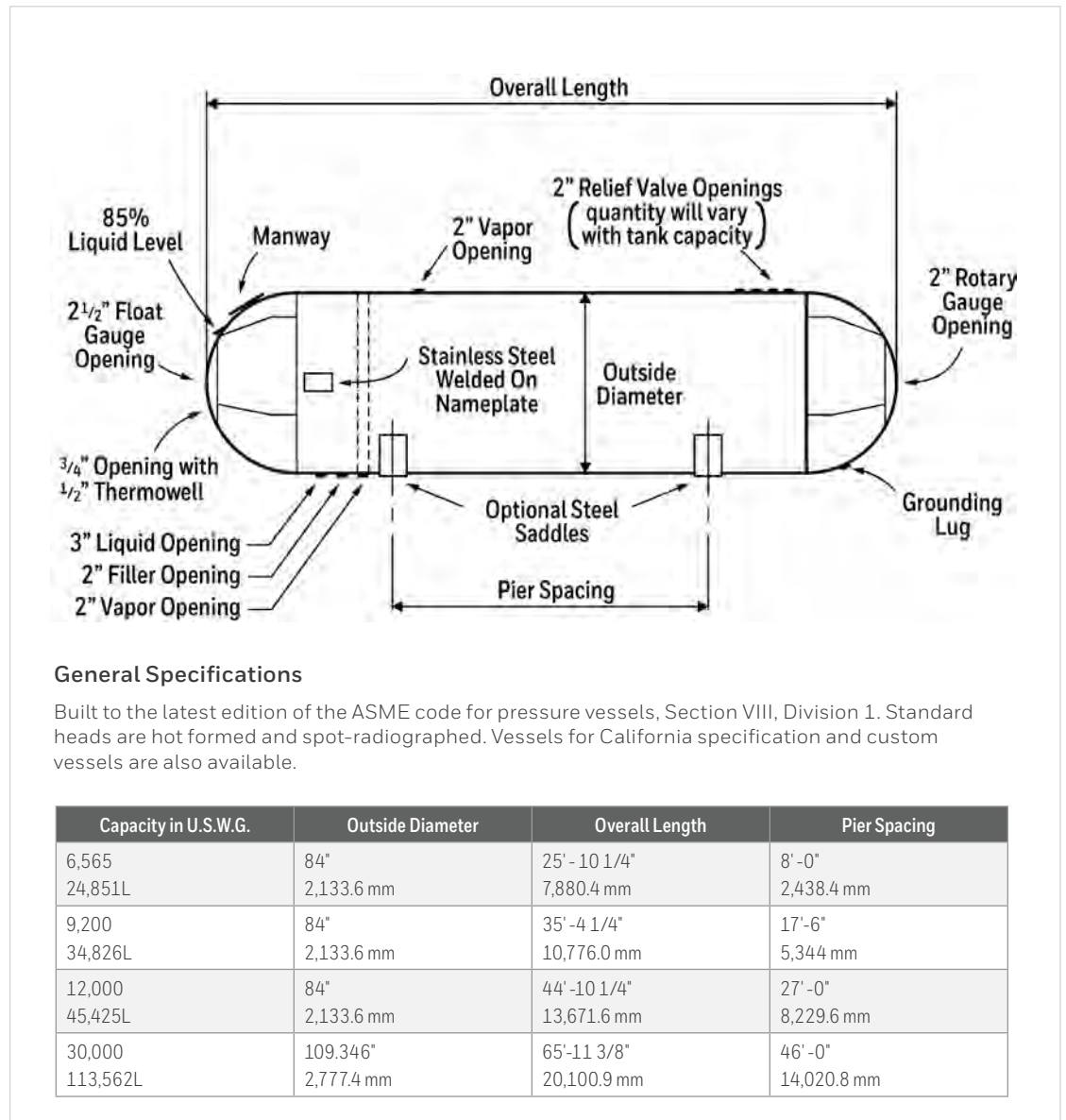

Drawing 1

## Bulk Storage Additional Details

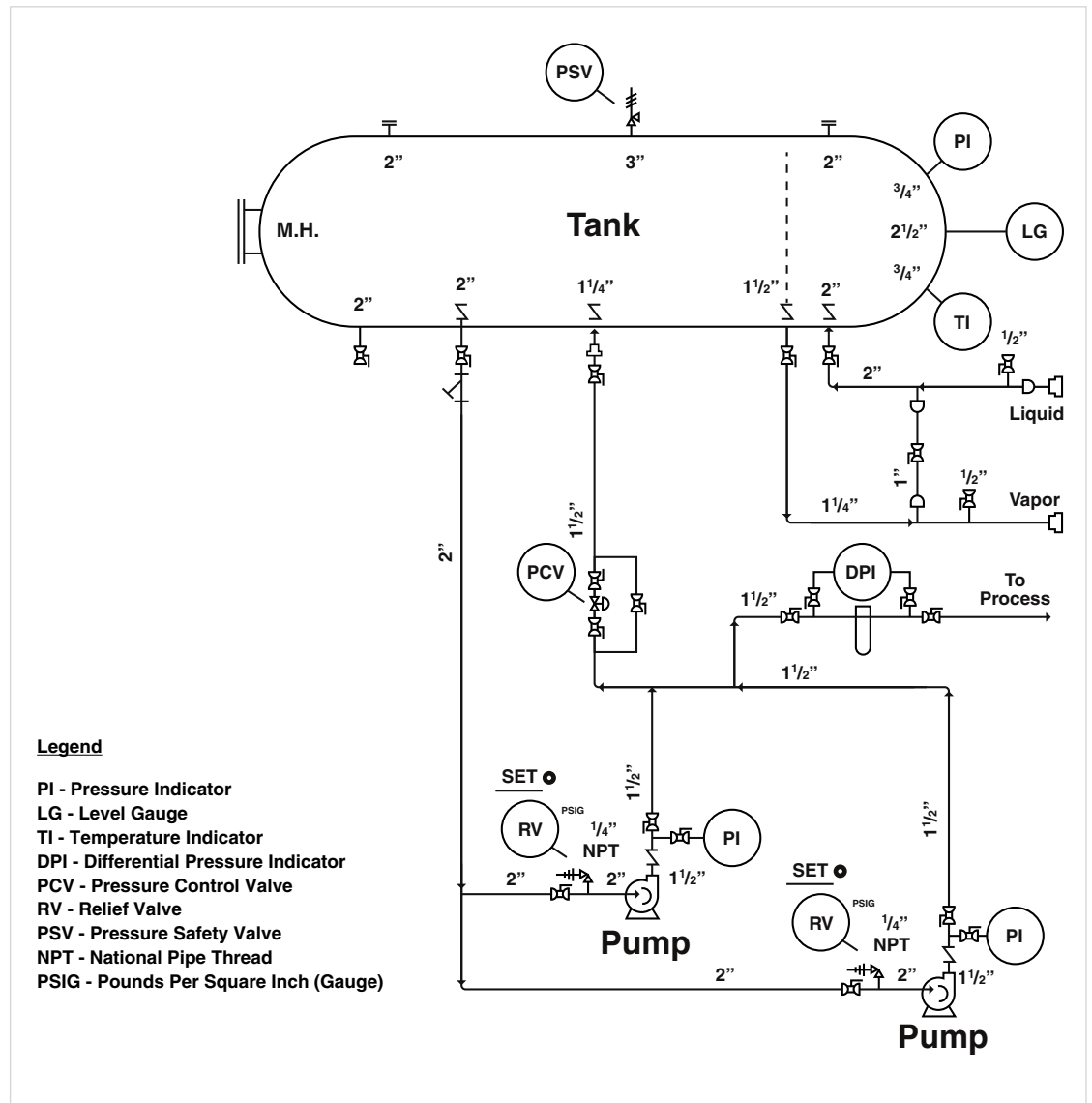

Drawing 2

## Bulk Transport Trailer to Tank Connection

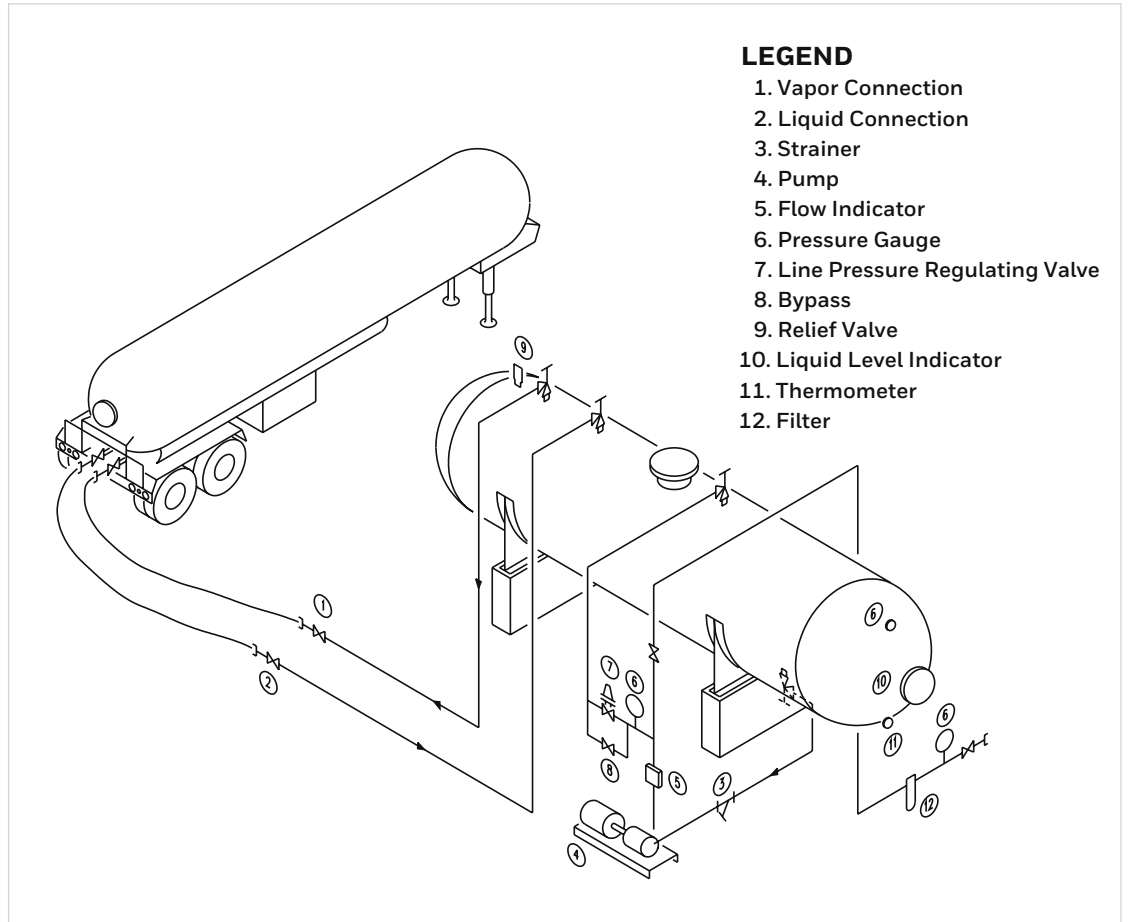

Drawing 3

## One-Ton Cylinders

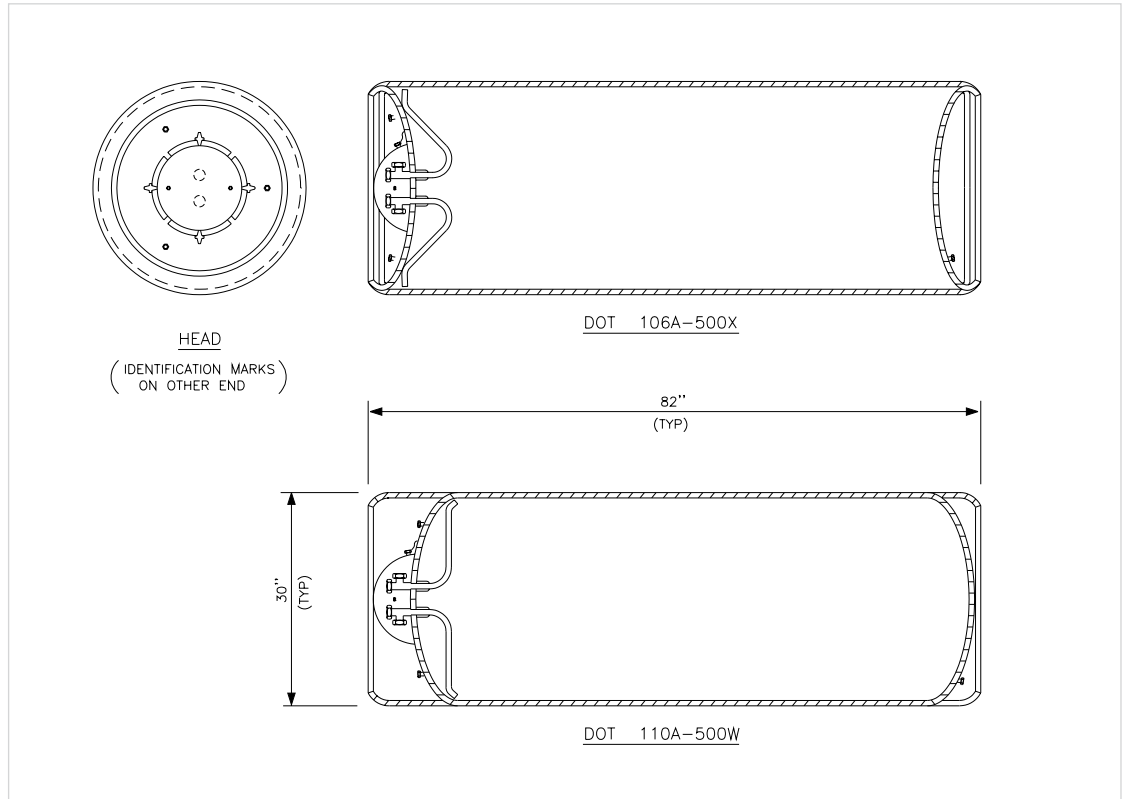

Drawing 4

## One-Ton Cylinder Pumping Configuration

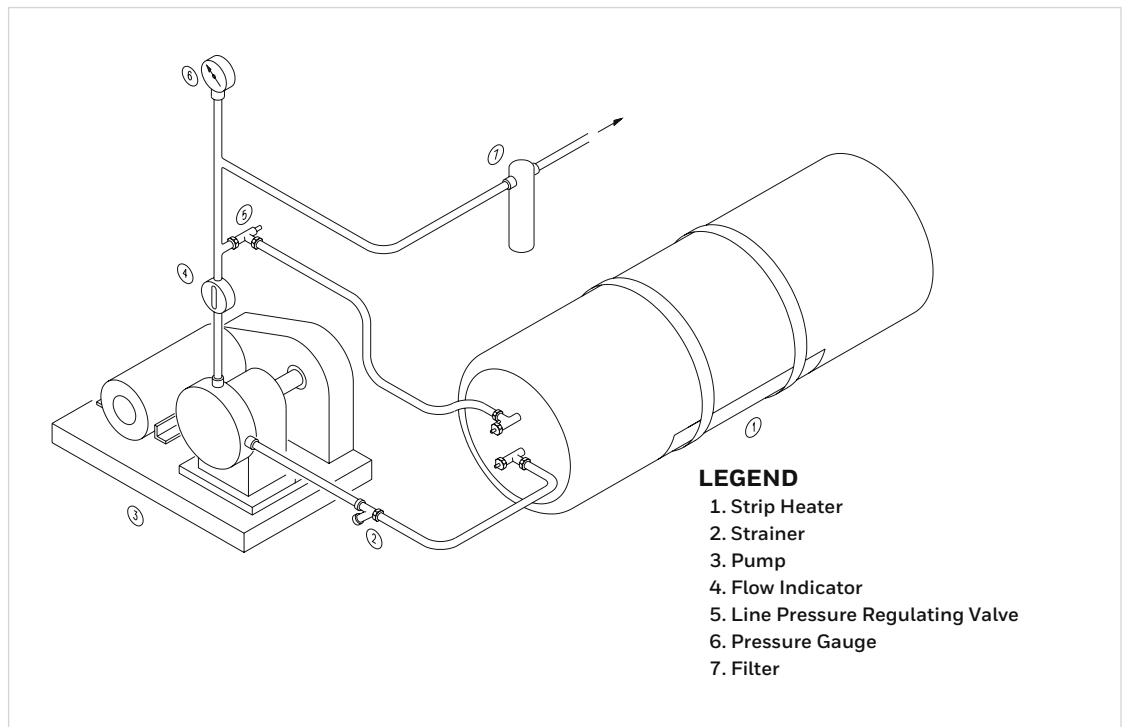

Drawing 5

## Typical Bulk Storage and PUR/PIR Master Batch Configuration

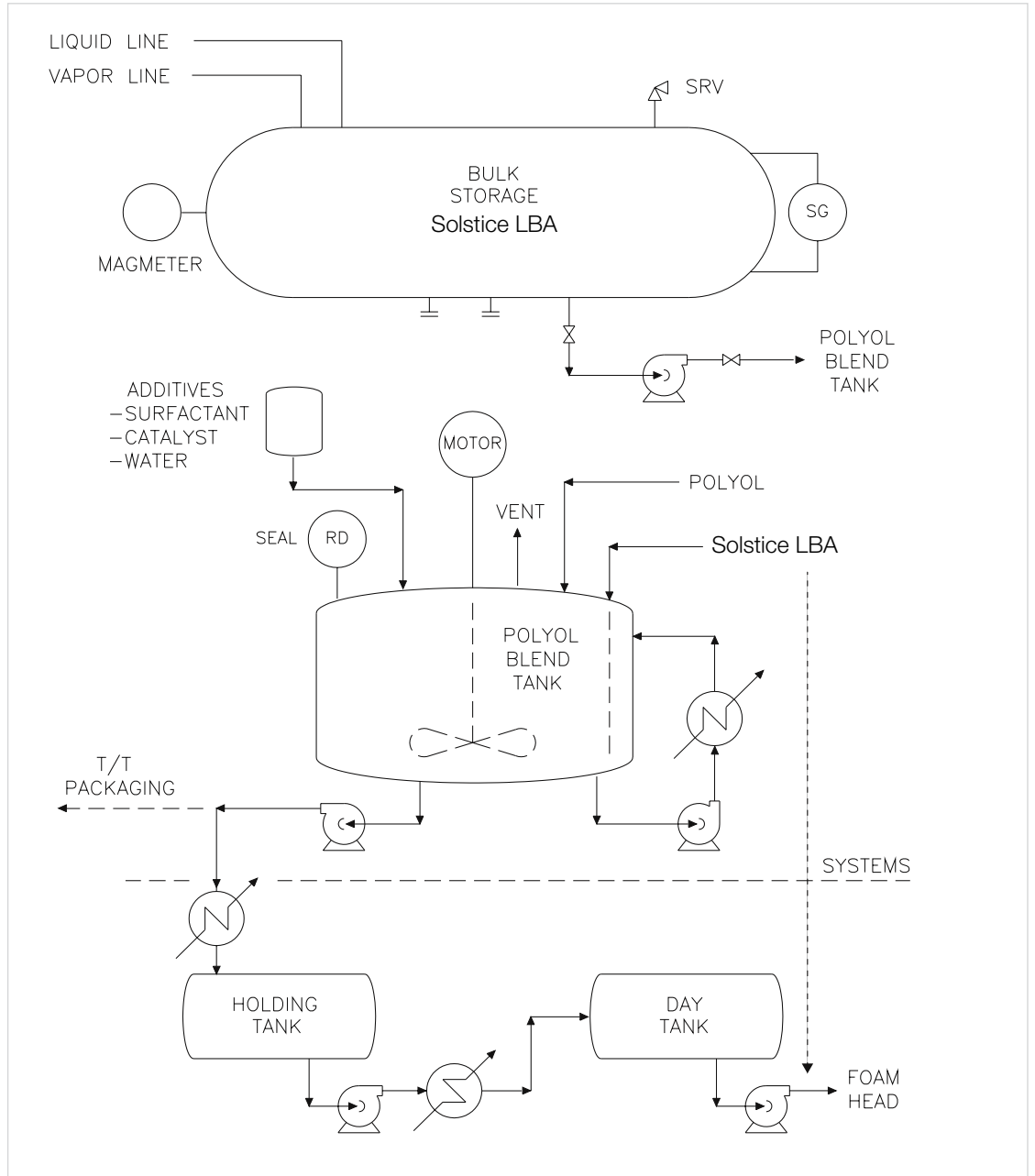

Drawing 6

## Package Piping Configuration: 100lb Cylinder

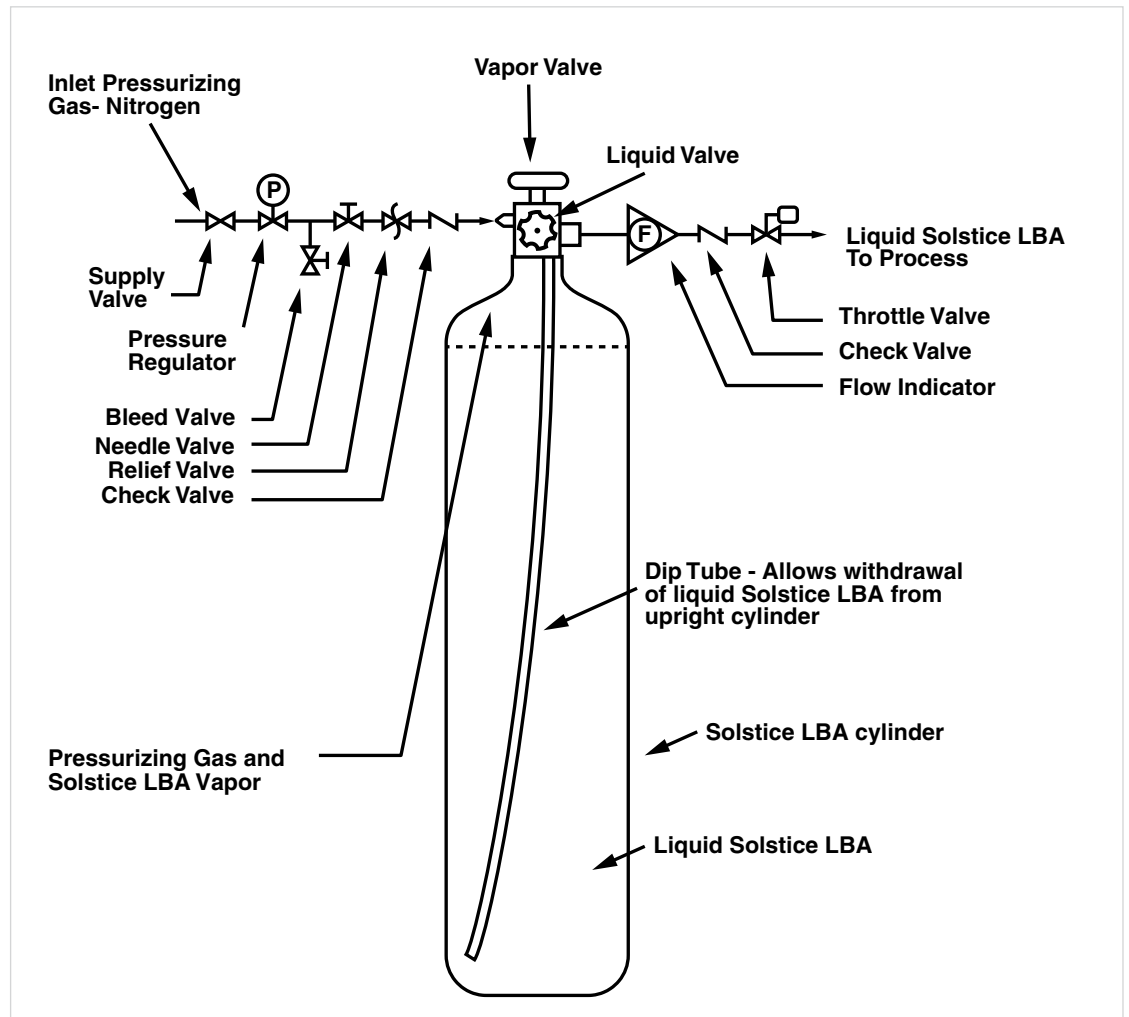

Drawing 7. Maximum Recommended Working Pressure: 260 PSIG

## Package Piping Configuration: One Half-Ton Cylinder

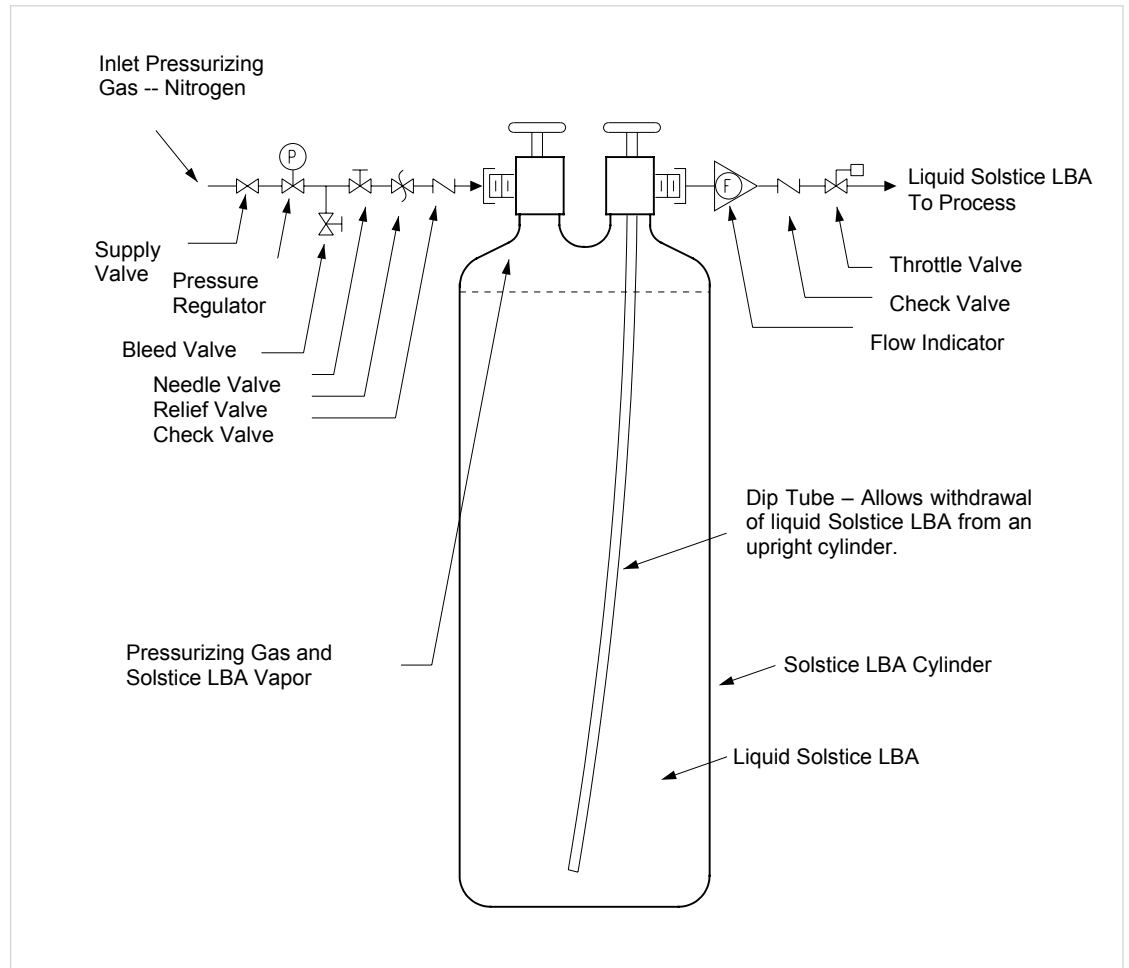

Drawing 8. Maximum Recommended Working Pressure: 260 PSIG

# Appendices

## Vapor Pressure of Blowing Agent\* – English Units<sup>37</sup>

<sup>37</sup> NIST Reference Fluid Properties (REFPROP) version 9.1

	CFC-11	HCFC-141b	HFC-245fa	Solstice LBA
Temperature (°F)	Pressure (psia)	Pressure (psia)	Pressure (psia)	Pressure (psia)
-40	0.738	0.450	0.830	0.805
-35	0.875	0.540	0.998	0.963
-30	1.032	0.645	1.194	1.146
-25	1.213	0.766	1.421	1.357
-20	1.419	0.905	1.684	1.599
-15	1.653	1.066	1.985	1.876
-10	1.918	1.249	2.331	2.191
-5	2.217	1.457	2.724	2.548
0	2.554	1.694	3.171	2.952
5	2.931	1.962	3.677	3.406
10	3.352	2.263	4.247	3.916
15	3.822	2.601	4.887	4.485
20	4.343	2.980	5.604	5.120
25	4.920	3.403	6.403	5.825
30	5.557	3.873	7.293	6.606
35	6.259	4.395	8.280	7.469
40	7.031	4.972	9.371	8.419
45	7.876	5.608	10.575	9.463
50	8.800	6.309	11.900	10.608
55	9.809	7.077	13.353	11.858
60	10.907	7.919	14.943	13.222
65	12.099	8.839	16.680	14.707
70	13.392	9.842	18.573	16.319
75	14.790	10.933	20.630	18.066
80	16.301	12.117	22.863	19.955
85	17.929	13.400	25.279	21.994
90	19.681	14.788	27.890	24.192
95	21.563	16.285	30.707	26.555
100	23.581	17.898	33.739	29.092
105	25.743	19.633	36.997	31.812
110	28.053	21.495	40.493	34.723
115	30.520	23.492	44.237	37.833
120	33.150	25.629	48.241	41.153
125	35.950	27.913	52.517	44.689
130	38.926	30.350	57.076	48.453
135	42.087	32.946	61.931	52.452
140	45.439	35.710	67.093	56.697
145	48.989	38.646	72.574	61.197
150	52.745	41.763	78.389	65.962
155	56.715	45.066	84.548	71.001
160	60.905	48.564	91.065	76.325

Table 11

\*These are but some of a mosaic of properties that must be evaluated in assessing candidate blowing agents.

## Vapor Pressure of Blowing Agent\* – SI Units<sup>38</sup>

<sup>38</sup> NIST Reference Fluid Properties  
(REFPROP) version 9.1

	CFC-11	HCFC-141b	HFC-245fa	Solstice LBA
Temperature (°C)	Pressure (kPa)	Pressure (kPa)	Pressure (kPa)	Pressure (kPa)
-40	5.088	3.106	5.720	5.553
-35	6.889	4.293	7.944	7.635
-30	9.192	5.841	10.853	10.330
-25	12.101	7.832	14.602	13.769
-20	15.730	10.358	19.369	18.099
-15	20.208	13.524	25.351	23.484
-10	25.674	17.448	32.771	30.104
-5	32.281	22.258	41.872	38.158
0	40.197	28.098	52.922	47.859
5	49.598	35.122	66.210	59.436
10	60.677	43.496	82.045	73.137
15	73.633	53.399	100.760	89.220
20	88.682	65.023	122.700	107.960
25	106.050	78.567	148.250	129.650
30	125.960	94.245	177.790	154.590
35	148.670	112.280	211.720	183.090
40	174.430	132.900	250.460	215.480
45	203.490	156.350	294.460	252.100
50	236.140	182.880	344.170	293.310
55	272.640	212.740	400.050	339.450
60	313.290	246.210	462.590	390.910
65	358.370	283.540	532.270	448.070
70	408.180	325.030	609.600	511.320

Table 12

\*These are but some of a mosaic of properties that must be evaluated in assessing candidate blowing agents.

### Solstice LBA Vapor Pressure Comparison (English Units)<sup>39</sup>

<sup>39</sup> NIST Reference Fluid Properties (REFPROP) version 9.1

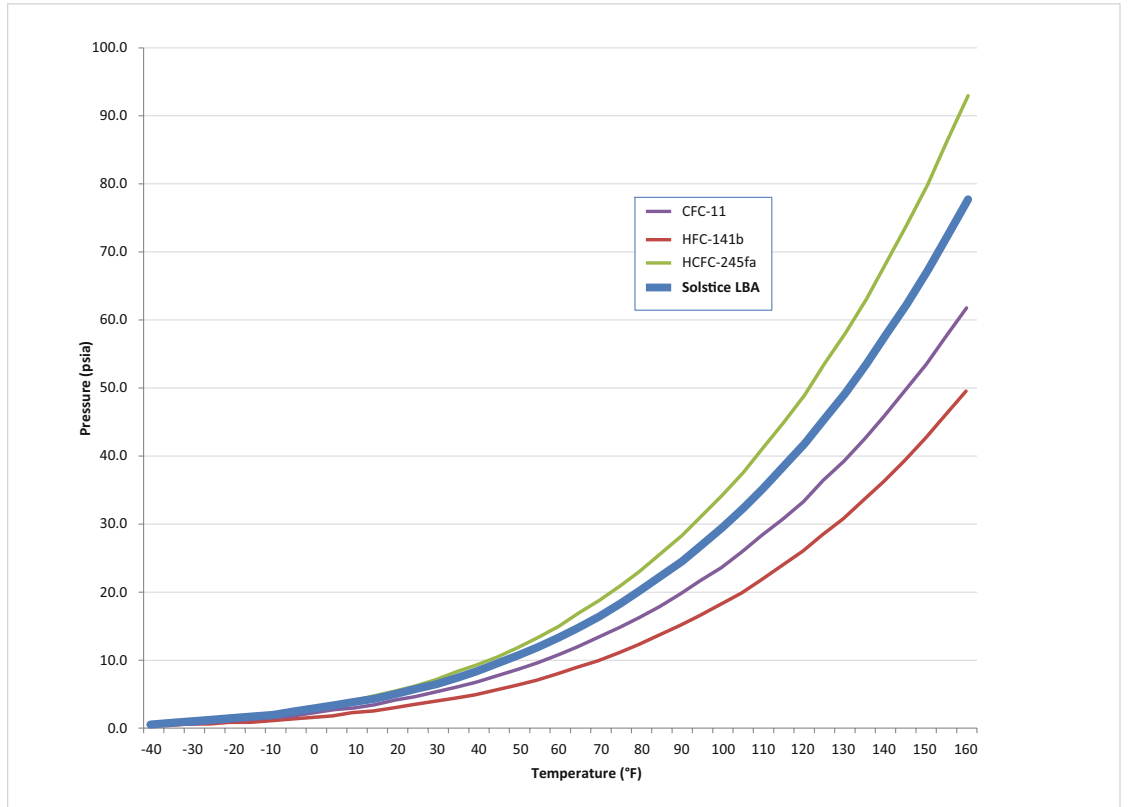

Figure 17

### Solstice LBA Vapor Pressure Comparison (SI Units)<sup>42</sup>

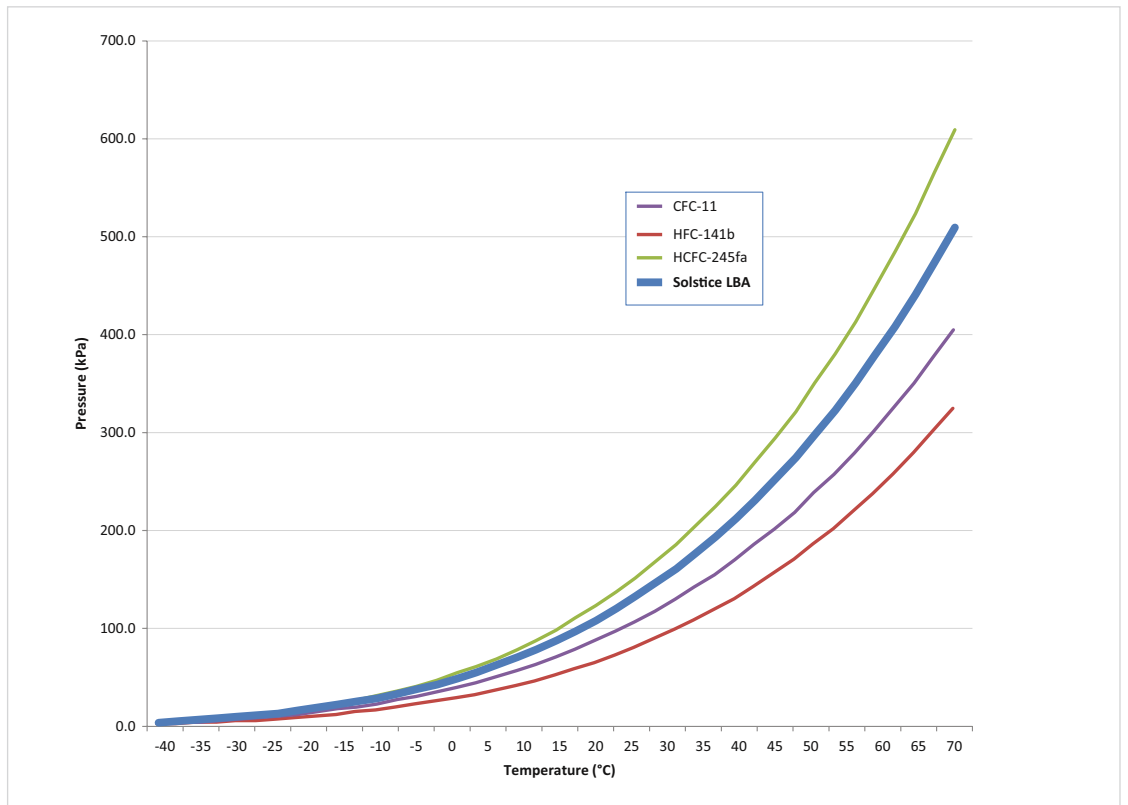

Figure 18

### For more information

To learn more about the benefits of Solstice® Liquid Blowing Agent, visit [sustainability.honeywell.com](https://sustainability.honeywell.com)

### Honeywell Advanced Materials

115 Tabor Road  
Morris Plains, NJ 07950  
[www.honeywell.com](https://www.honeywell.com)



Although Honeywell International Inc. believes that the information contained herein is accurate and reliable, it is presented without guarantee or responsibility of any kind and does not constitute any representation or warranty of Honeywell International Inc., either expressed or implied. A number of factors may affect the performance of any products used in conjunction with user's materials, such as other raw materials, application, formulation, environmental factors and manufacturing conditions among others, all of which must be taken into account by the user in producing or using the products. The user should not assume that all necessary data for the proper evaluation of these products are contained herein. Information provided herein does not relieve the user from the responsibility of carrying out its own tests and experiments, and the user assumes all risks and liabilities (including, but not limited to, risks relating to results, patent infringement, regulatory compliance and health, safety and environment) related to the use of the products and/or information contained herein.

Solstice is a registered trademark of Honeywell International Inc.  
1595 FP BA | v18 | 02/22  
© 2022 Honeywell International Inc.

**THE  
FUTURE  
IS WHAT  
WE  
MAKE IT**

---

**Honeywell**